

EPHL FN ACCESSORIES

1. Cable tensioner

Air Cable tensioner : two heavy air-cylinders working to keep the cable strongest tightened on drum, while the winch is in the free spool mode.

To keep the cable severely tightened on drum, Vime has designed and engineered an Air Cable tensioner with heavy bracket, rugged lever arm (1a) and hardened steel bar (2b), controlled by two reinforced air-cylinders (3c).

Available for:

EPHL 10000FN – EPHL 12500FN – EPHL 15000FN – EPHL 16500FN
EPHL 18000FN - EPHL 20000FN – EPHL 22500FN – EPHL 25000FN

Note : for models EPHL 15000FN - EPHL 16500FN - EPHL 20000FN
EPHL 22500FN – EPHL 25000FN the Air cable tensioner works without the Heavy-duty roller fairlead only.

PRESSURE	6 BAR	8 BAR	10 BAR
	87 Psi	116 Psi	145 Psi
FORCE	150 KG.	200 KG.	250 KG.

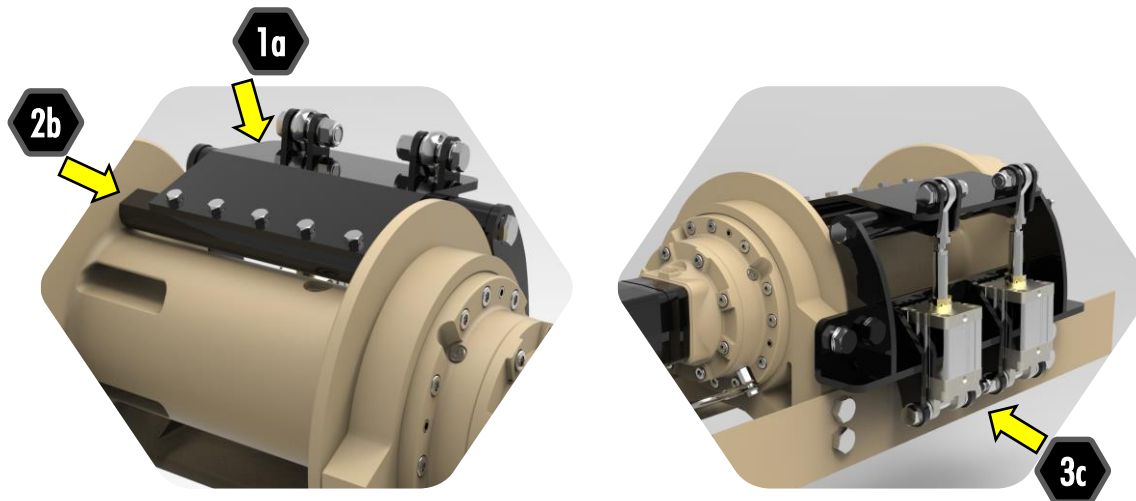
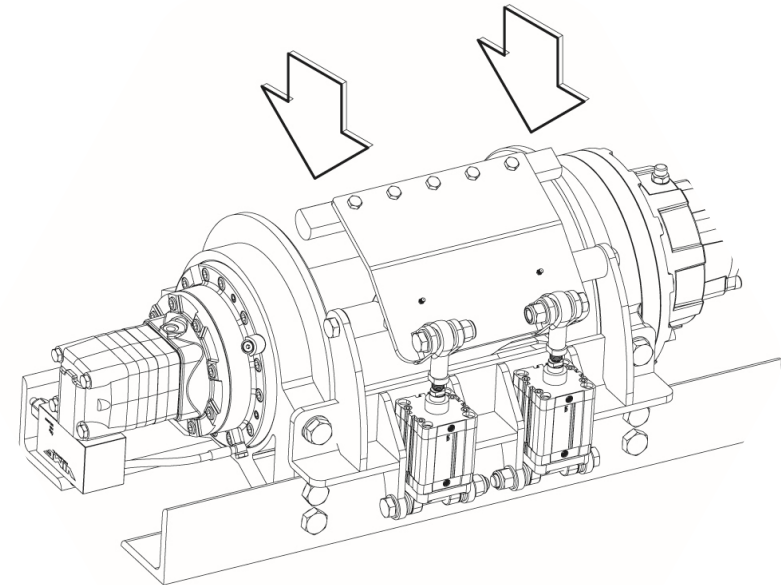

© copyright V.I.M.E. srl

All the projects of our devices and products are covered and protected by copyright V.I.M.E. Beware of imitations and/or distributors or dealers not authorized, V.I.M.E. devices and products are exclusively conceived, projected, produced and assembled by V.I.M.E. in Italy.