

Machinery Directive 2006/42/CE
EN 14492-1

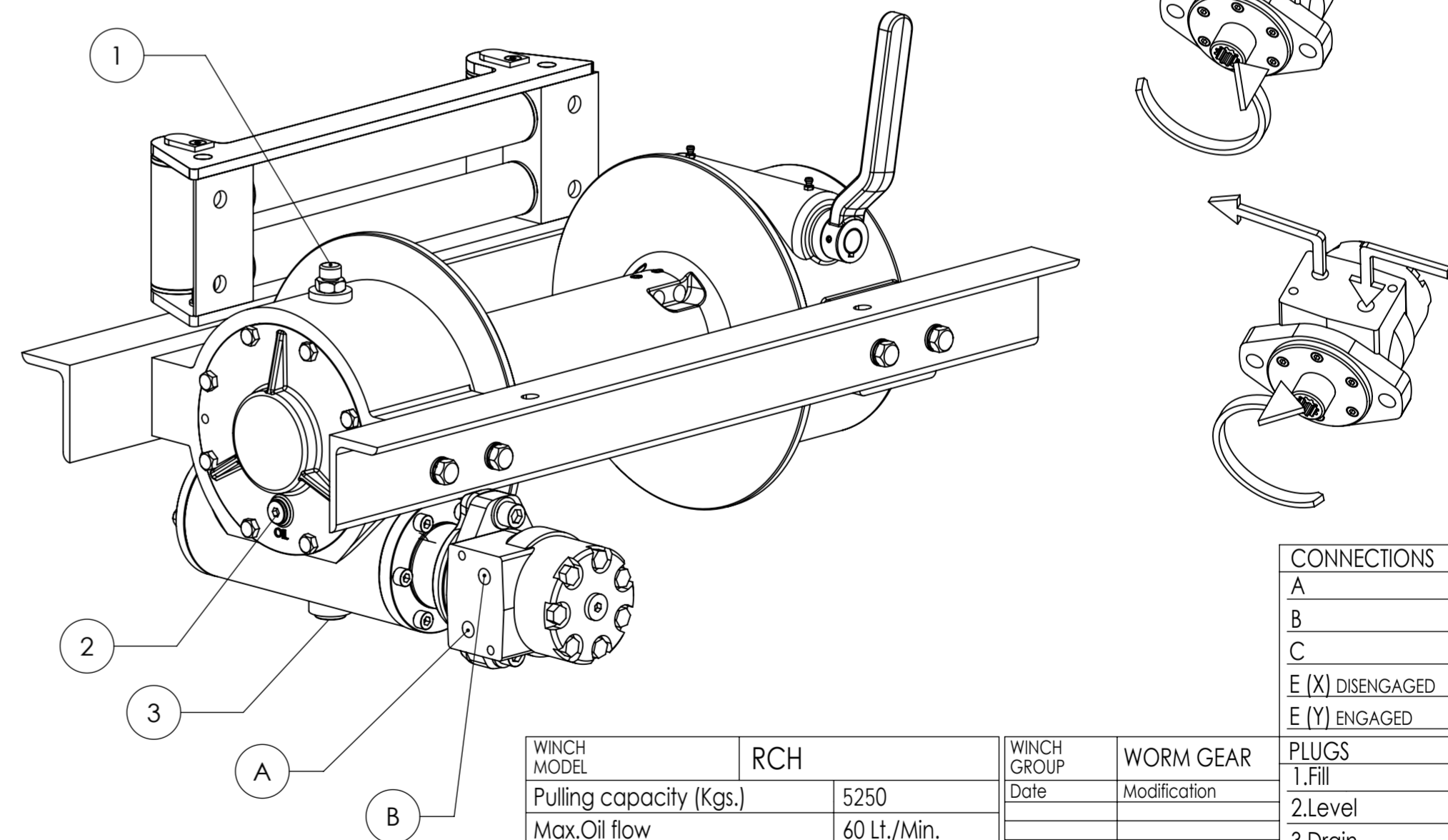
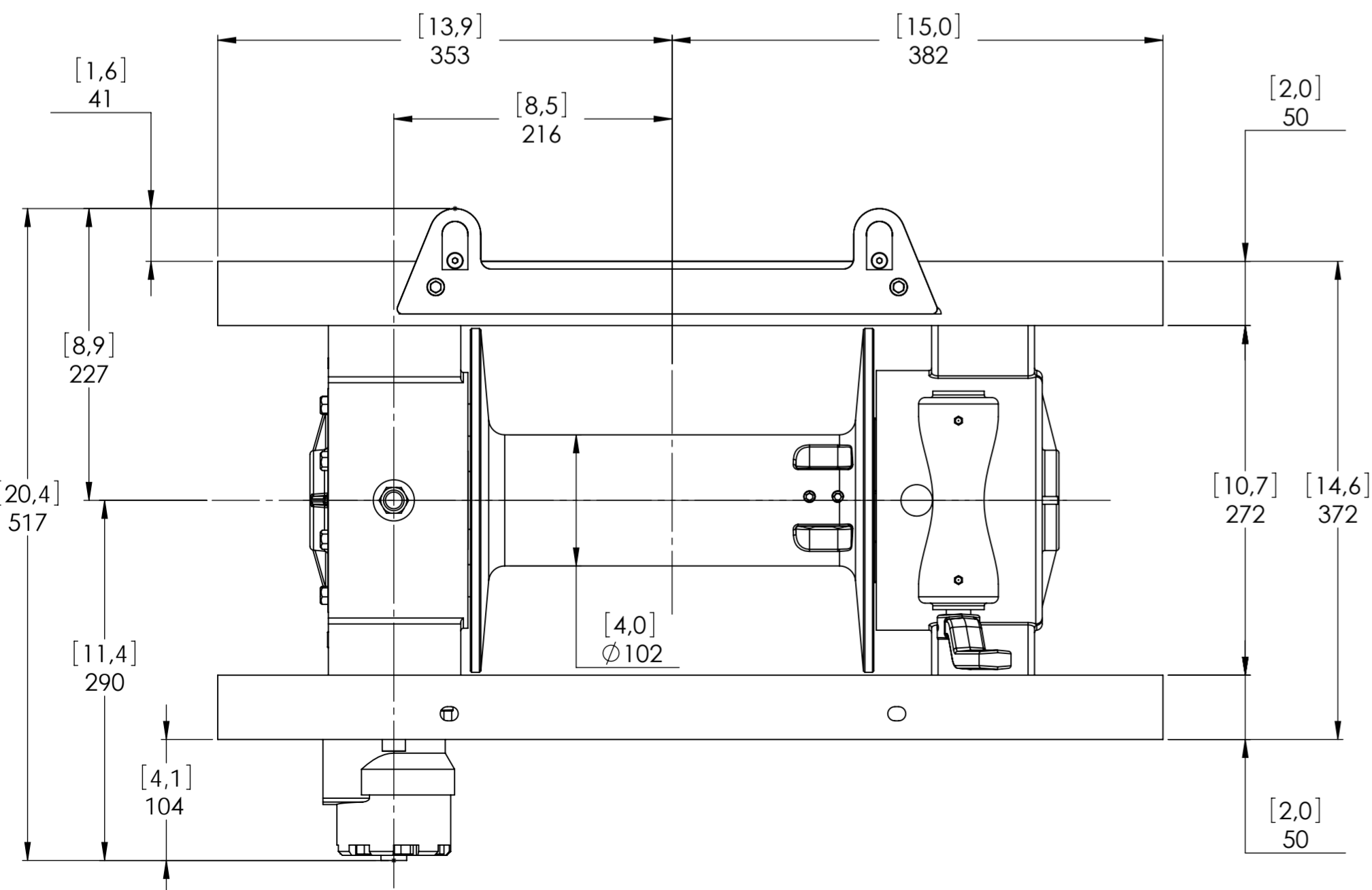
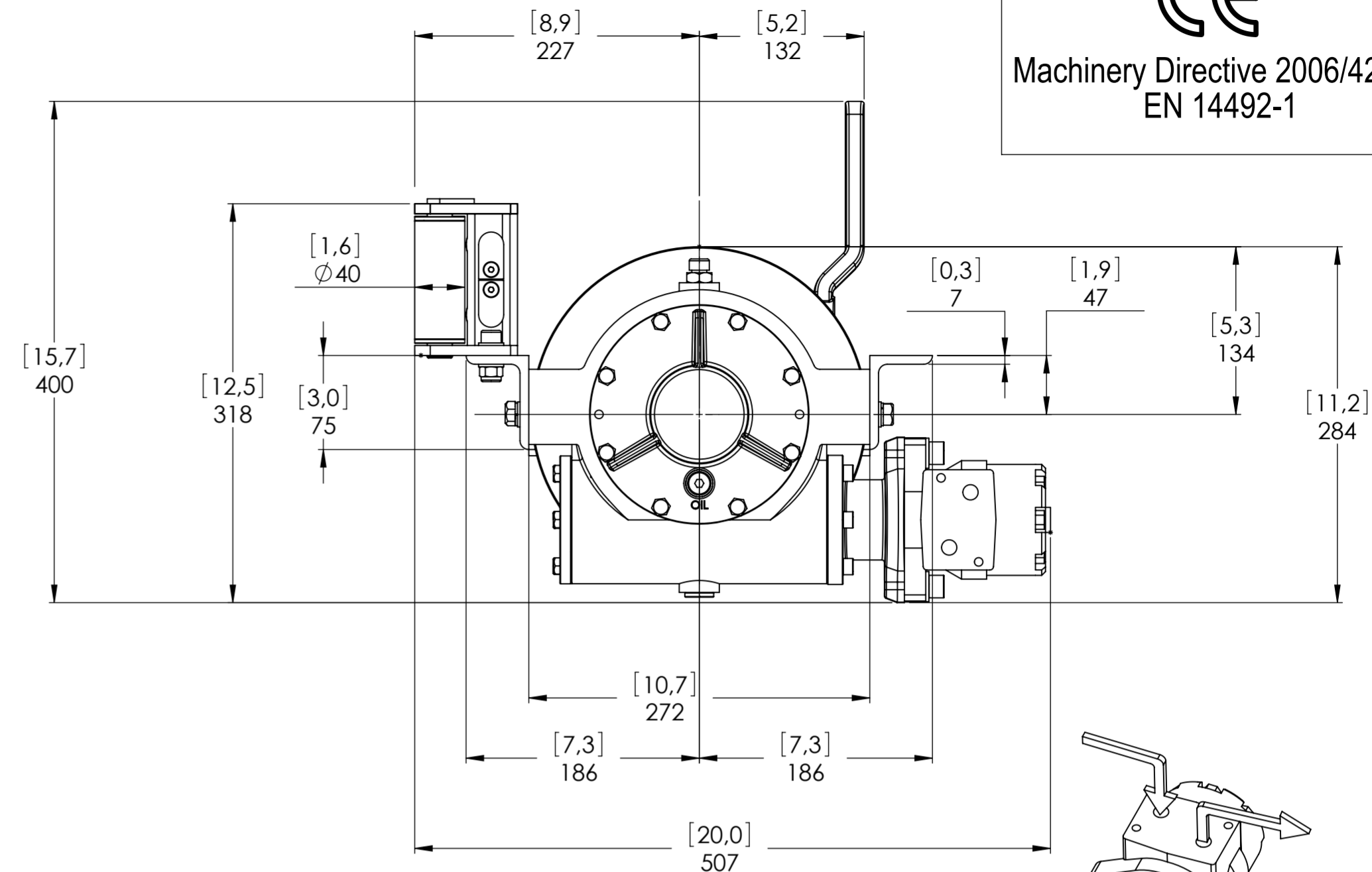
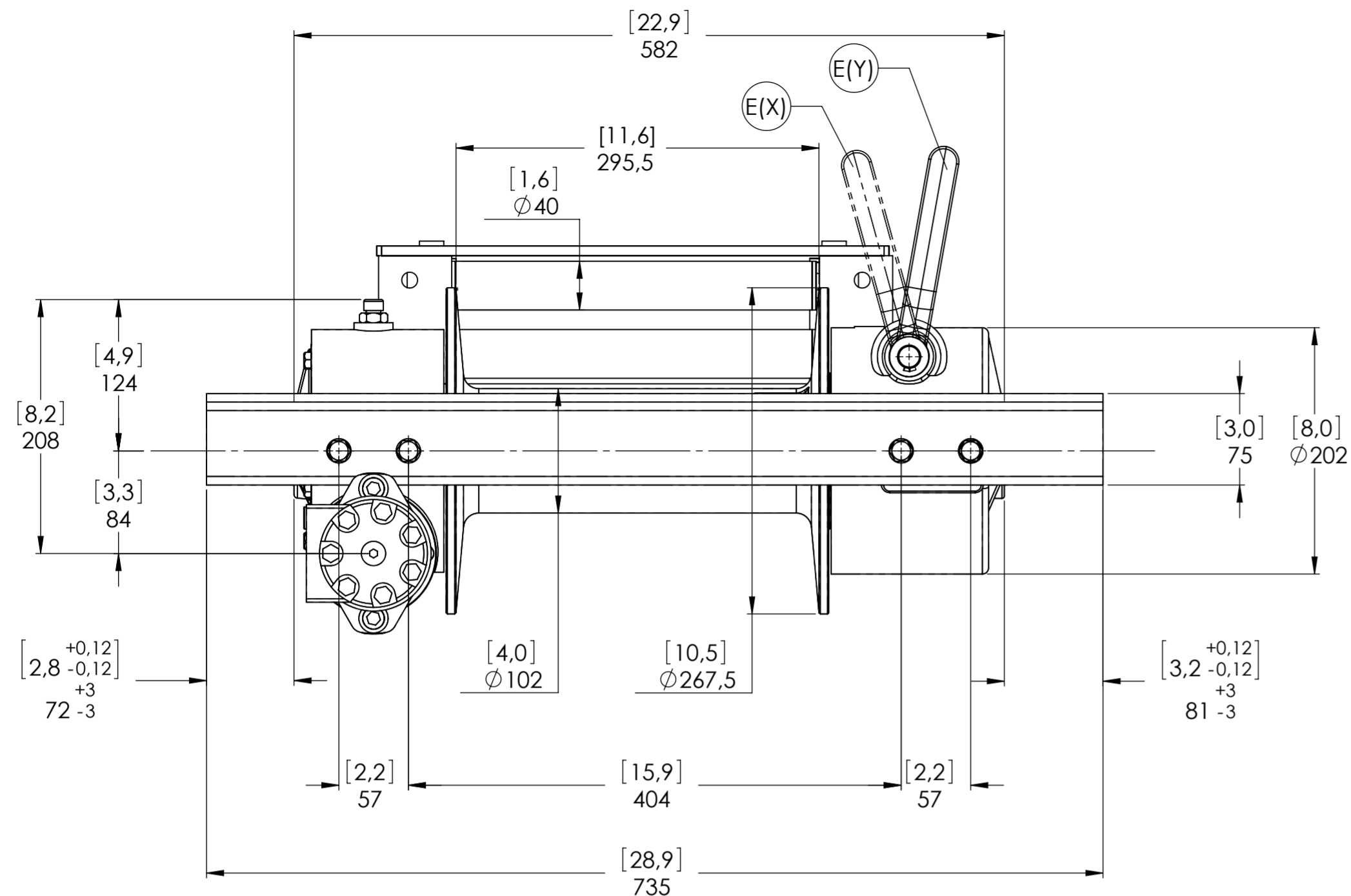

CONNECTIONS	
A	1/2" G
B	1/2" G
C	-----
E (X) DISENGAGED	-----
E (Y) ENGAGED	-----

PLUGS	
1.Fill	3/8" G
2.Level	1/4" G
3.Drain	3/8" G

SCALE 1:4

WEIGHTS	
Winch (without oil)	58 Kgs.
Roller fairlead	----
Heavy-duty roller fairlead	9,6 Kgs.
Rope tensioner	----

CODE RCH52K160GR

WINCH MODEL	RCH	WINCH GROUP	WORM GEAR
Pulling capacity (Kgs.)	5250	Date	Modification
Max.Oil flow	60 Lt./Min.		
Speed Line - first layer	4,3 Mt./Min.	DANGEROUS: Do not use winch to lift support or transport personnel.	
Speed Line - top layer	7,6 Mt./Min.		

Gear ratio	29:1
Orbital hydr. motor	160 cc
Working pressure	140
Drum size	295,5
Drum clutch	Manual



Funo - Bologna (Italy)
www.vimeindustrial.com

The Quality is Transparent

VIME Industrial reserves the right to improve its products through changes in designed or materials as it may seem desirable without notice

DATE 12/05/2010

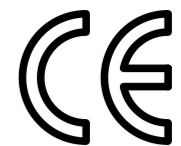

Machinery Directive 2006/42/CE
EN 14492-1

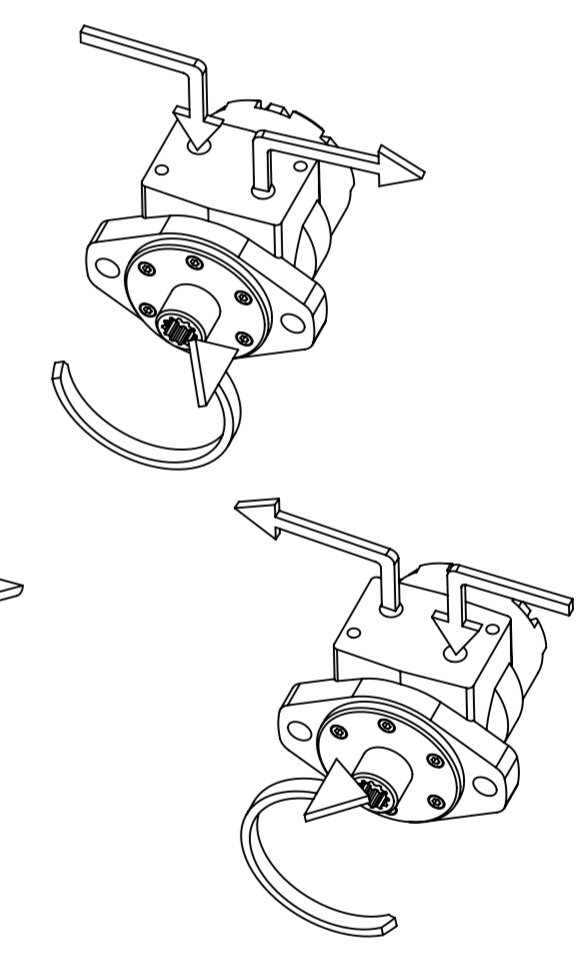
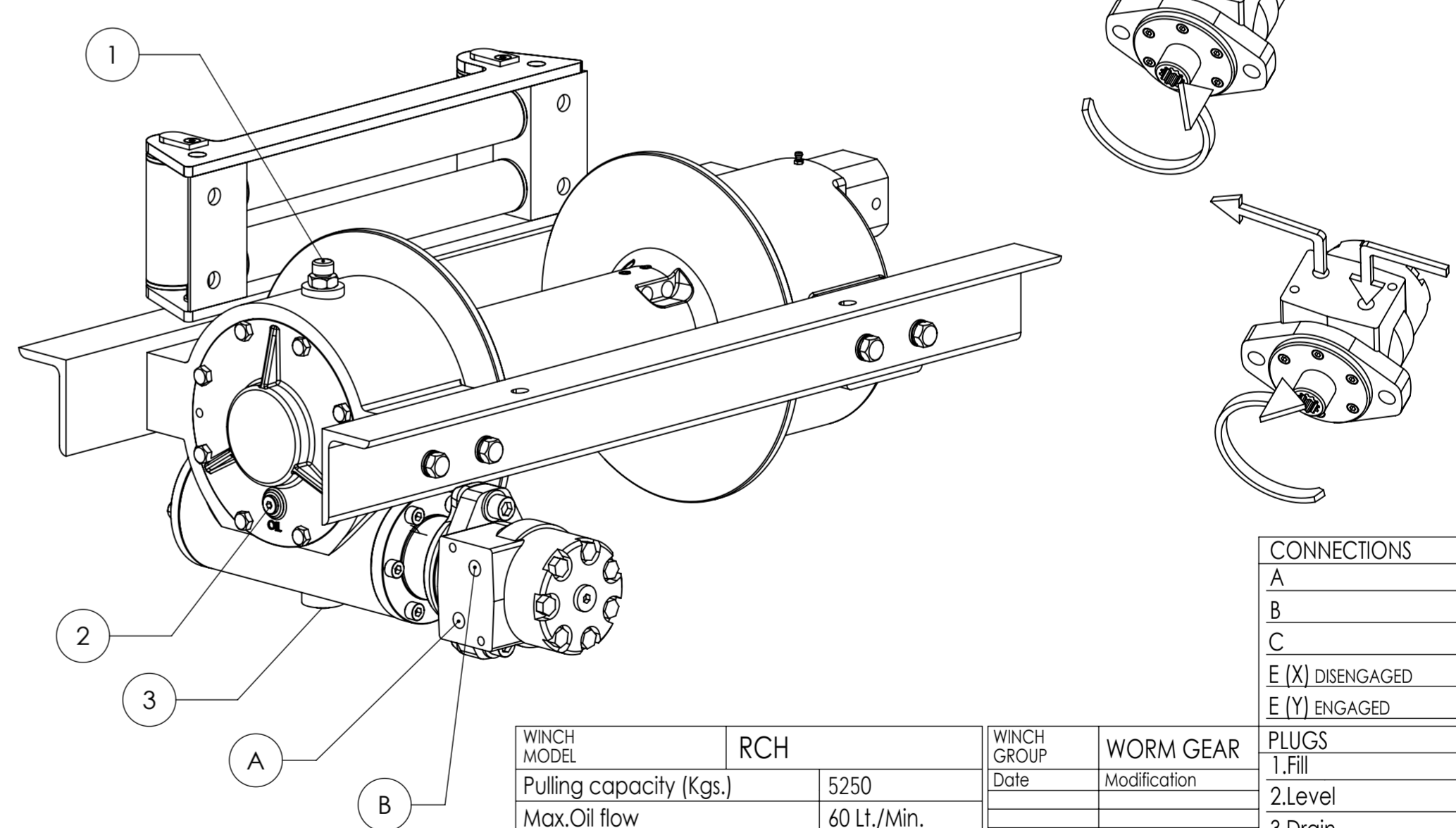
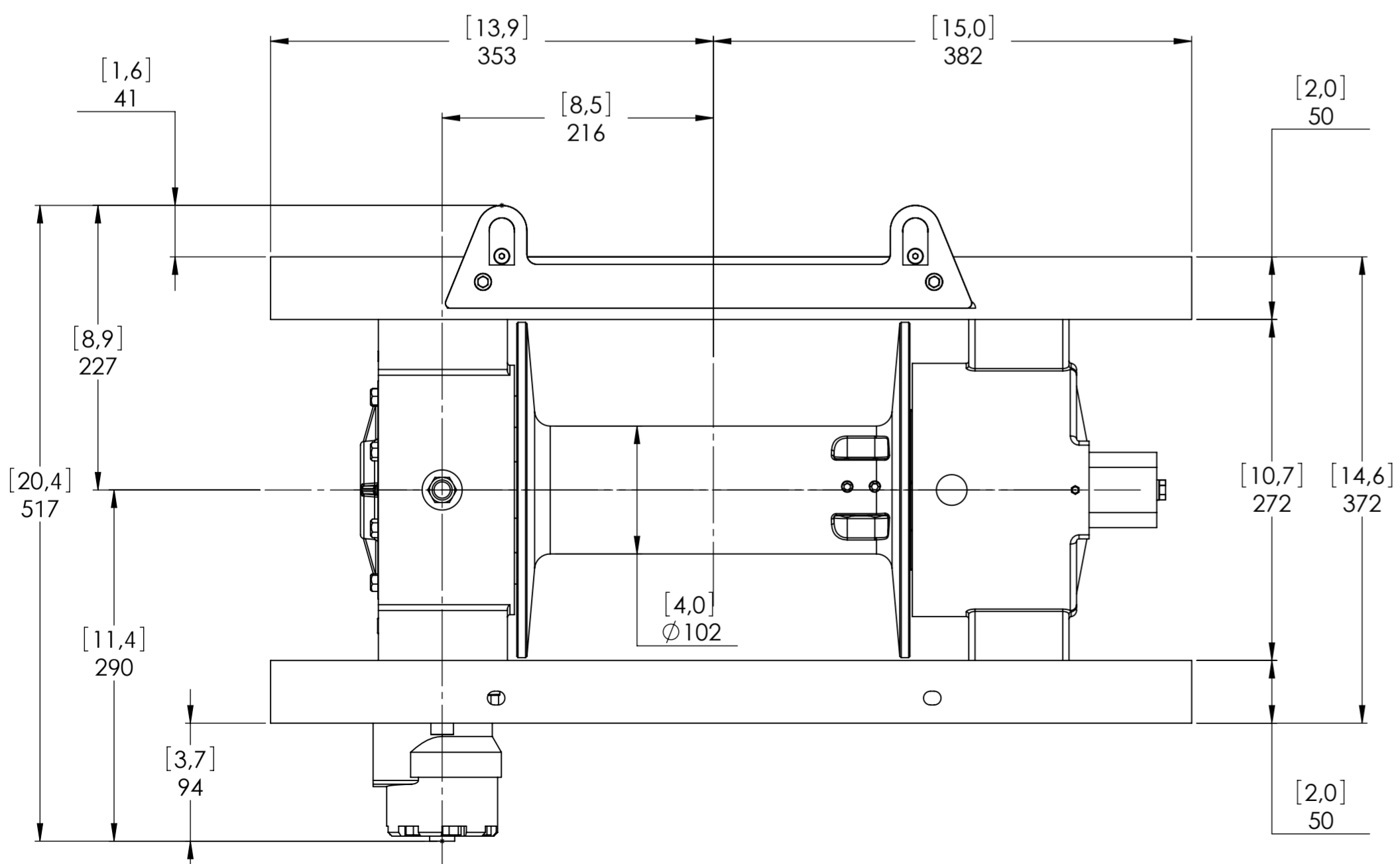
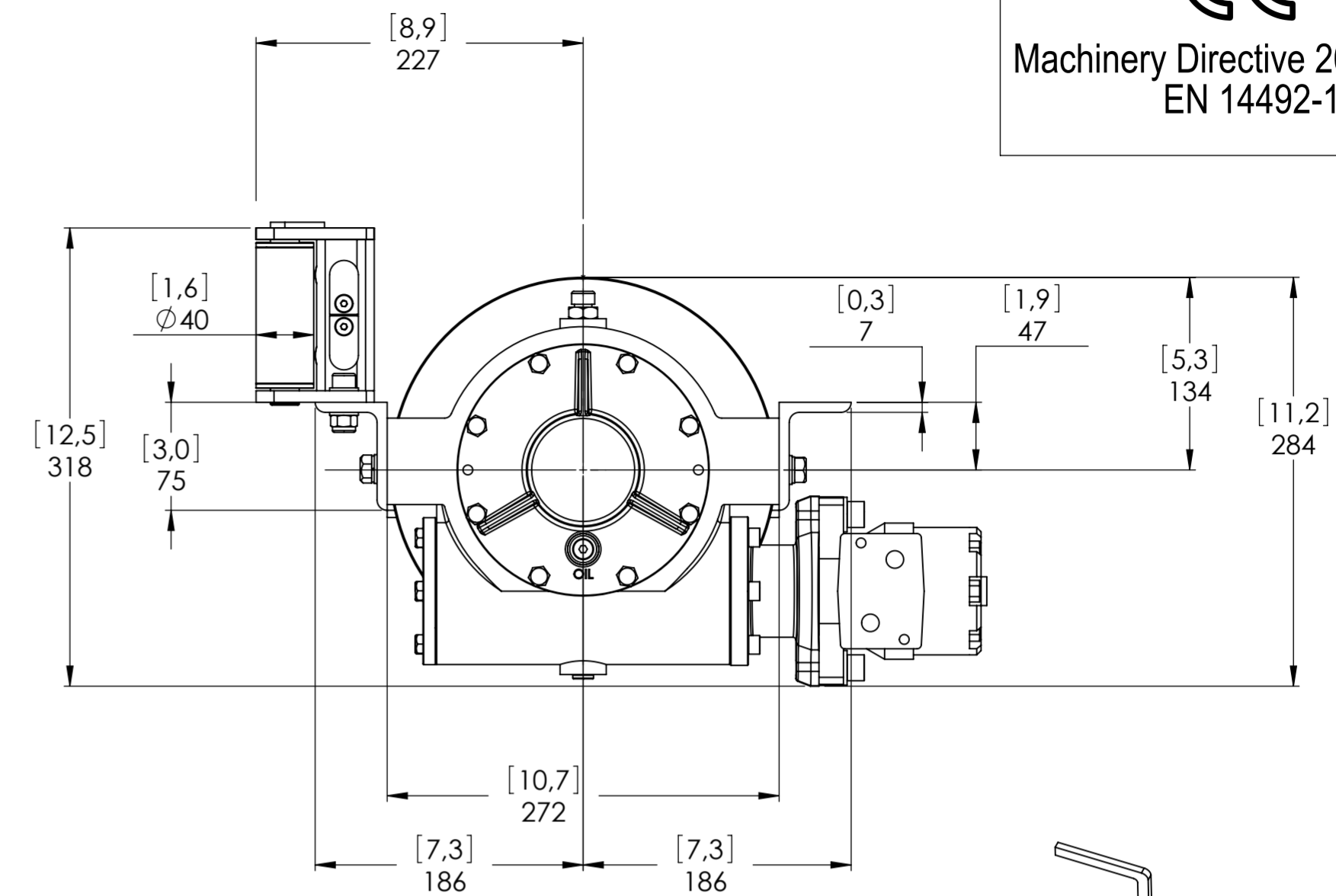
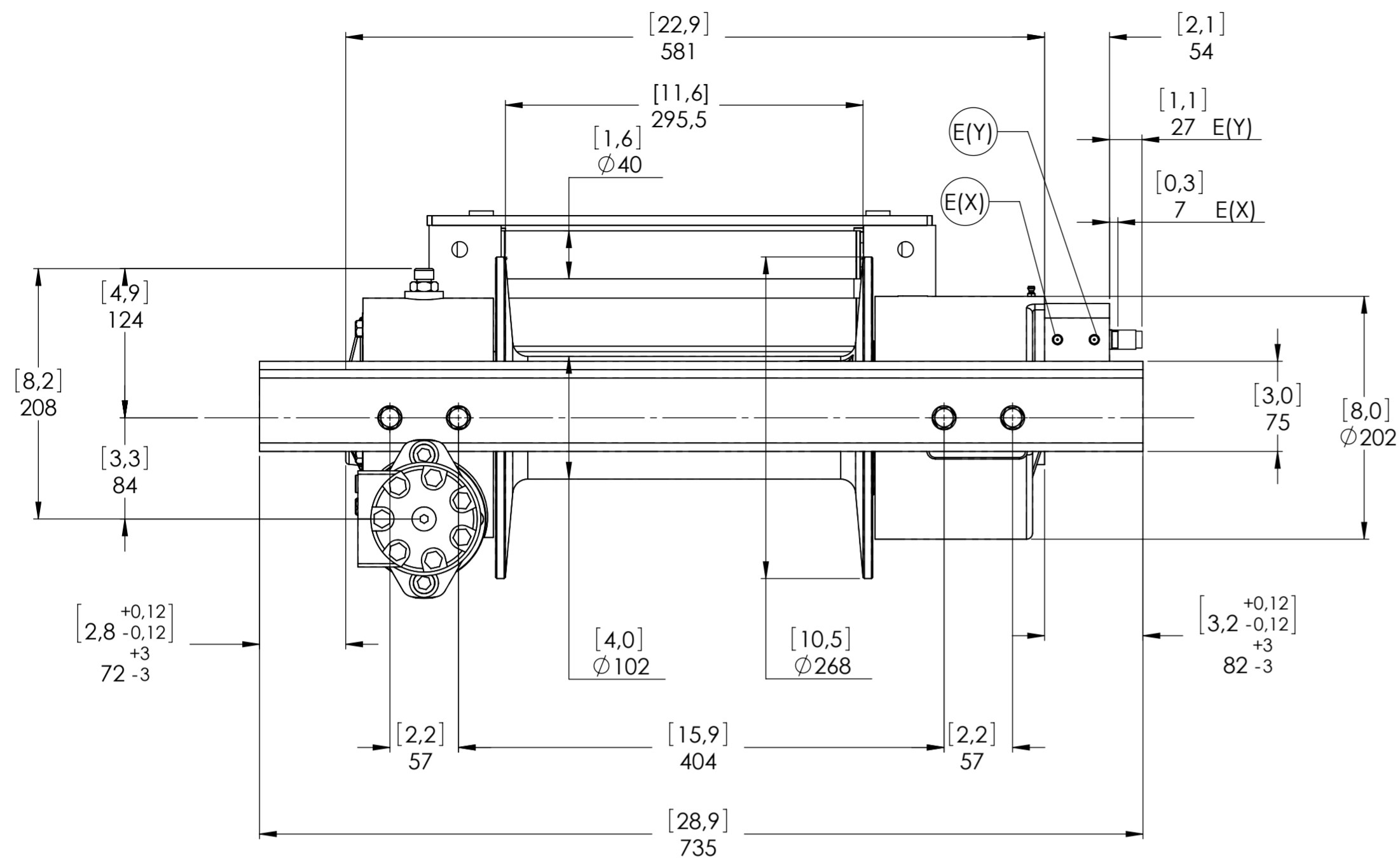

WINCH MODEL	RCH	WINCH GROUP	WORM GEAR
Pulling capacity (Kgs.)	5250	Date	Modification
Max.Oil flow	60 Lt./Min.		
Speed Line - first layer	4,3 Mt./Min.	DANGEROUS: Do not use winch to lift support or transport personnel.	
Speed Line - top layer	7,6 Mt./Min.		

Gear ratio	29:1
Orbital hydr. motor	160 cc
Working pressure	140
Drum size	295,5
Drum clutch	Air-operated

Funo - Bologna (Italy)
www.vimeindustrial.com

The Quality is Transparent

VIME Industrial : reserves the right to improve its products through changes in designed or materials as it may seem desirable without notice

DATE 12/05/2010

CONNECTIONS	
A	1/2"G
B	1/2"G
C	-----
E (X) DISENGAGED	1/8"G
E (Y) ENGAGED	1/8"G

PLUGS	
1.Fill	3/8"G
2.Level	1/4"G
3.Drain	3/8"G

SCALE	1:4
-------	-----

WEIGHTS	
Winch (without oil)	58 Kgs.
Roller fairlead	-----
Heavy-duty roller fairlead	9,6 Kgs.
Rope tensioner	-----

CODE RCH52K160AGR

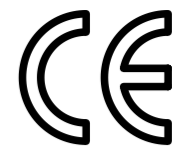

Machinery Directive 2006/42/CE
EN 14492-1

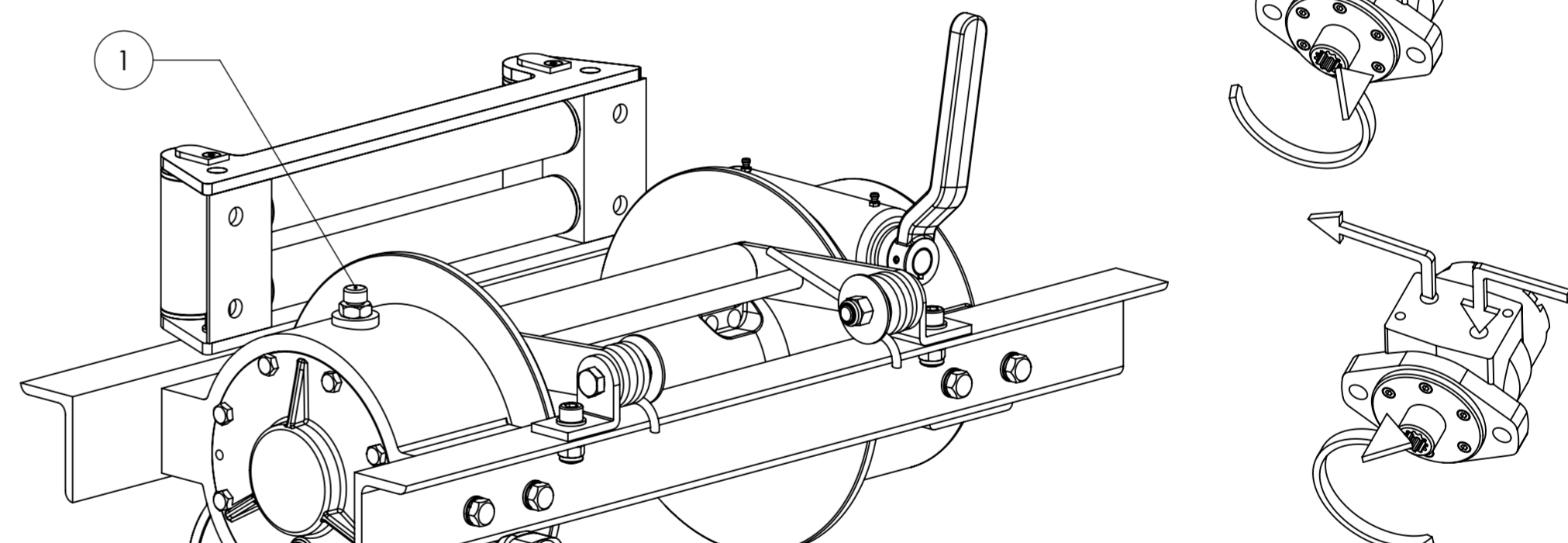
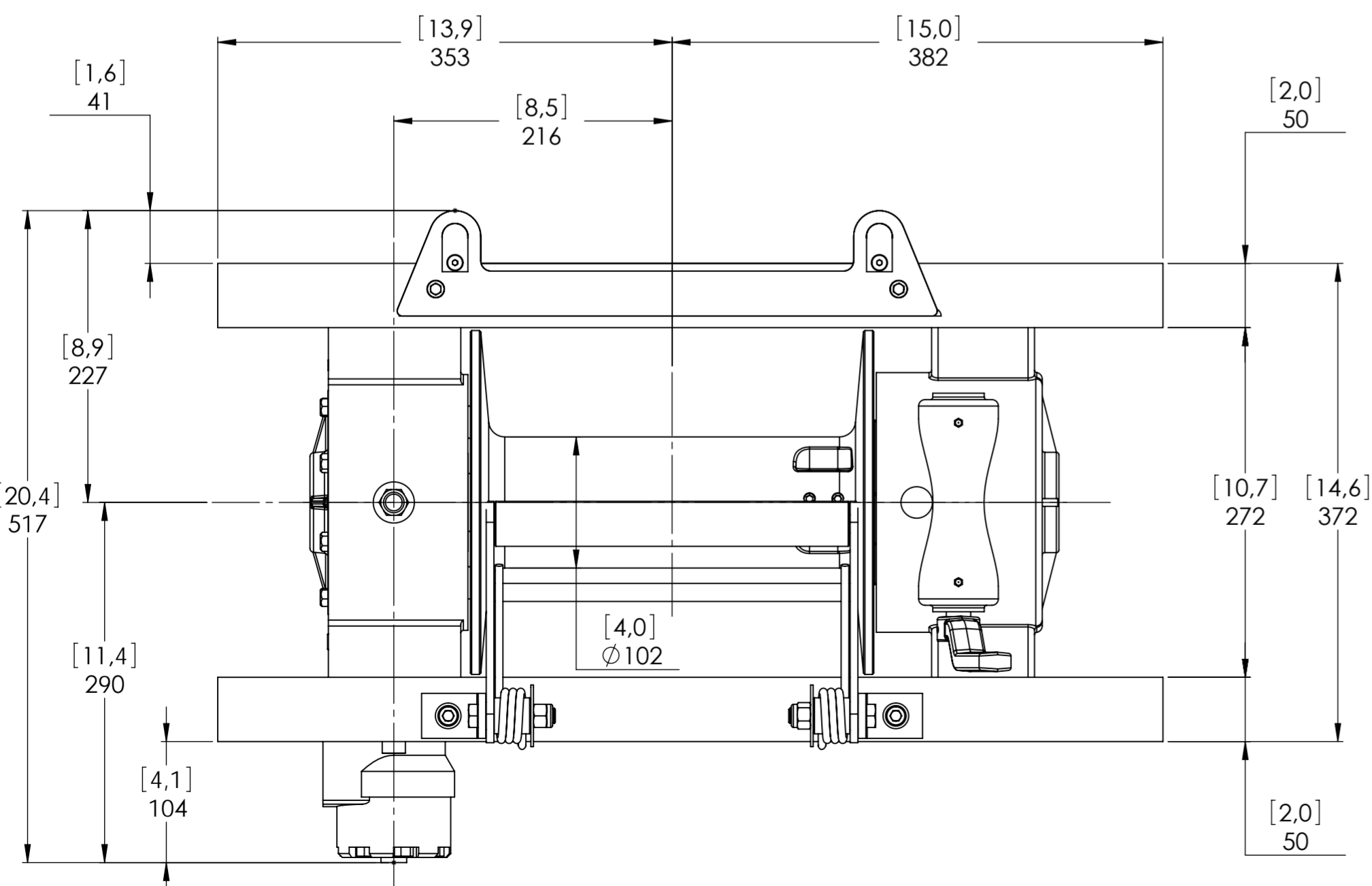
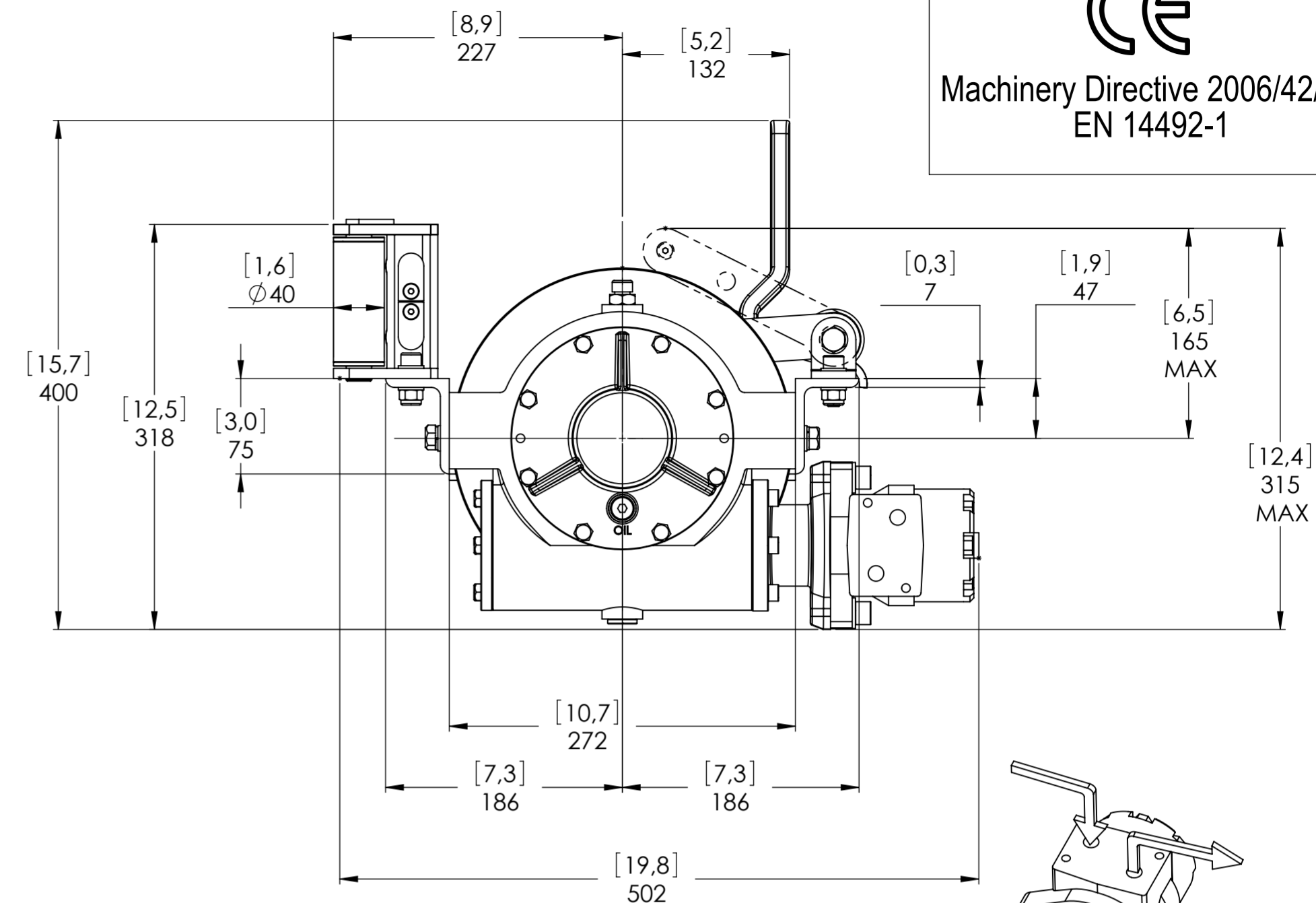
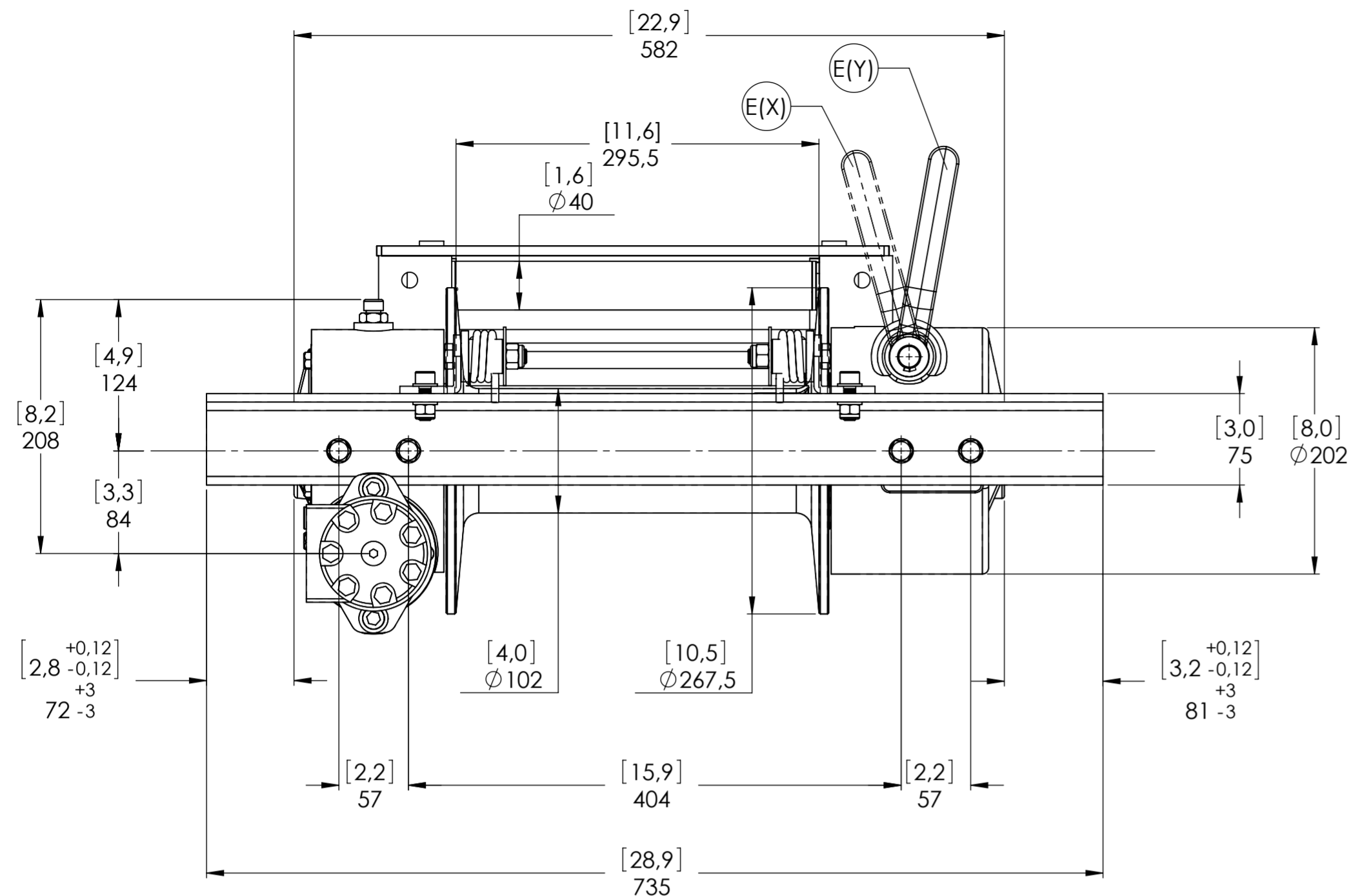

CONNECTIONS	
A	1/2" G
B	1/2" G
E (X) DISENGAGED	----
E (Y) ENGAGED	----

PLUGS	
1.Fill	3/8" G
2.Level	3/8" G
3.Drain	3/8" G

SCALE	
	1:4

WEIGHTS	
Winch (without oil)	58 Kg
Roller fairlead	----
Heavy-duty roller fairlead	9.6 Kg
Rope tensioner	2.2 Kg

CODE RCH52K160GRP

WINCH MODEL	RCH	WINCH GROUP	WORM GEAR
Pulling capacity (Kgs.)	5250	Date	Modification
Max.Oil flow	60 Lt./Min.		
Speed Line - first layer	4.3 Mt./Min.		
Speed Line - top layer	7.6 Mt./Min.		

DANGEROUS: Do not use winch to lift support or transport personnel.

Gear ratio	29:1
Orbital hydr. motor	160 cc
Working pressure	140
Drum size	295,5
Drum clutch	Manual



Funo - Bologna (Italy)
www.vimeindustrial.com

The Quality is Transparent

VIME Industrial reserves the right to improve its products through changes in designed or materials as it may seem desirable without notice

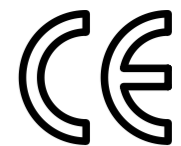

Machinery Directive 2006/42/CE
EN 14492-1

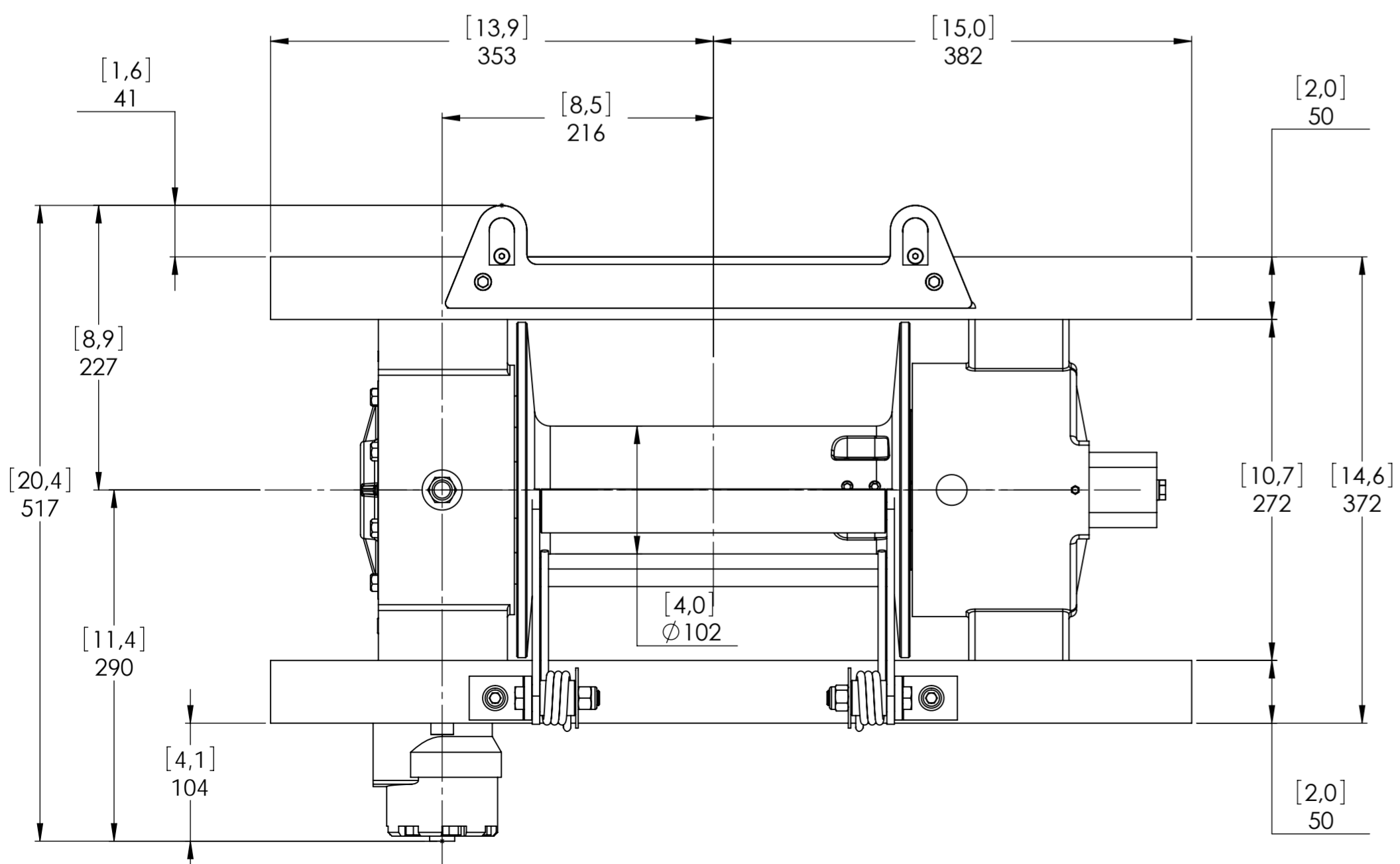
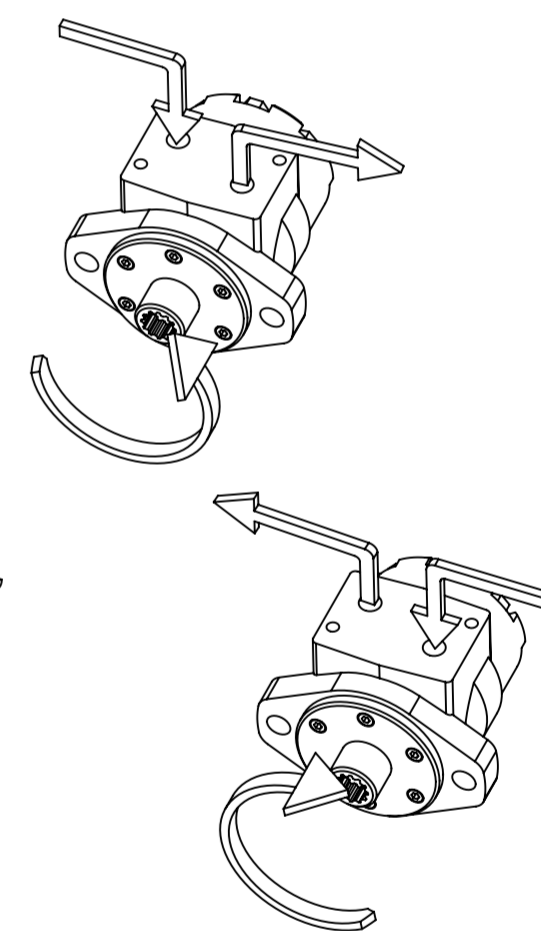
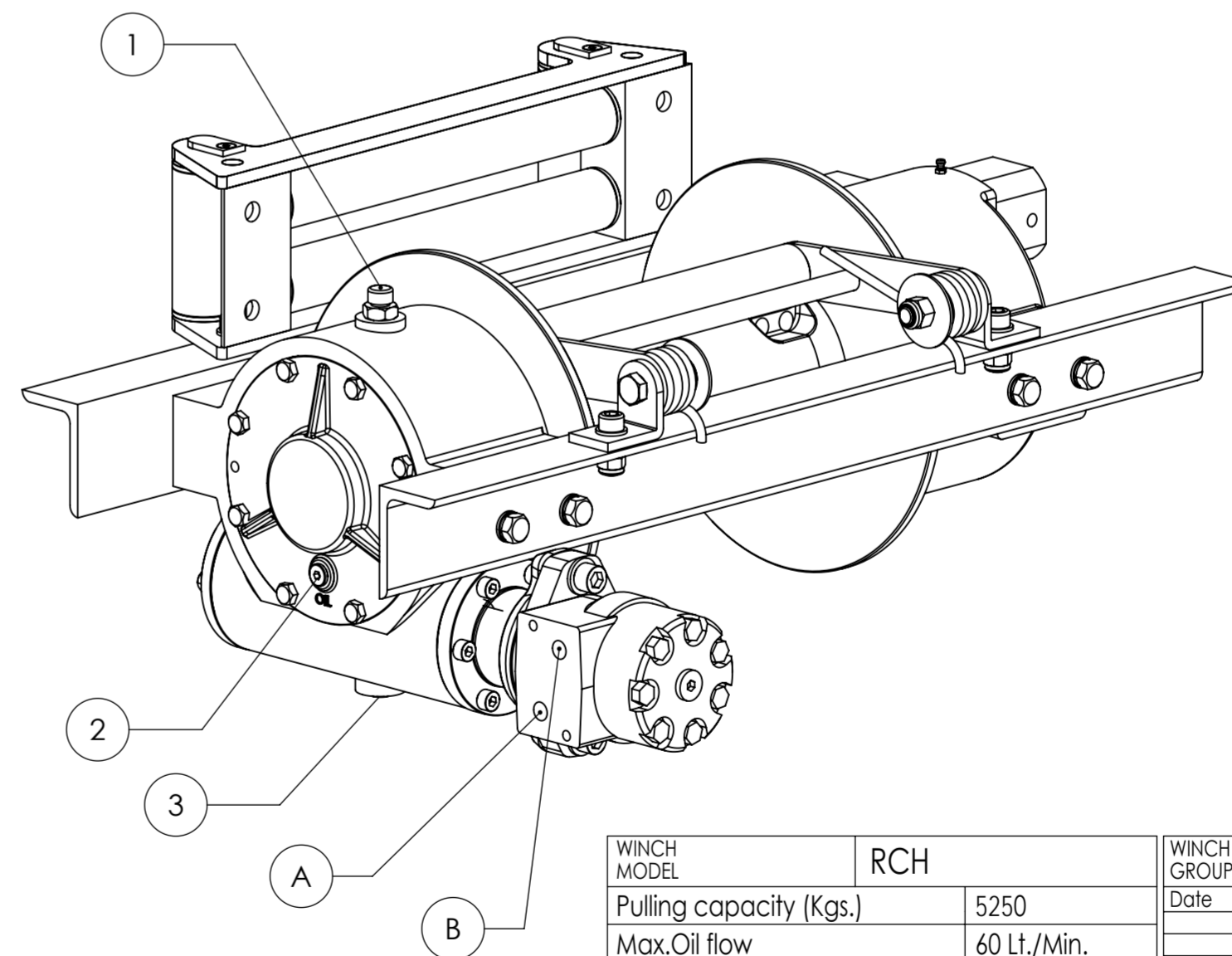
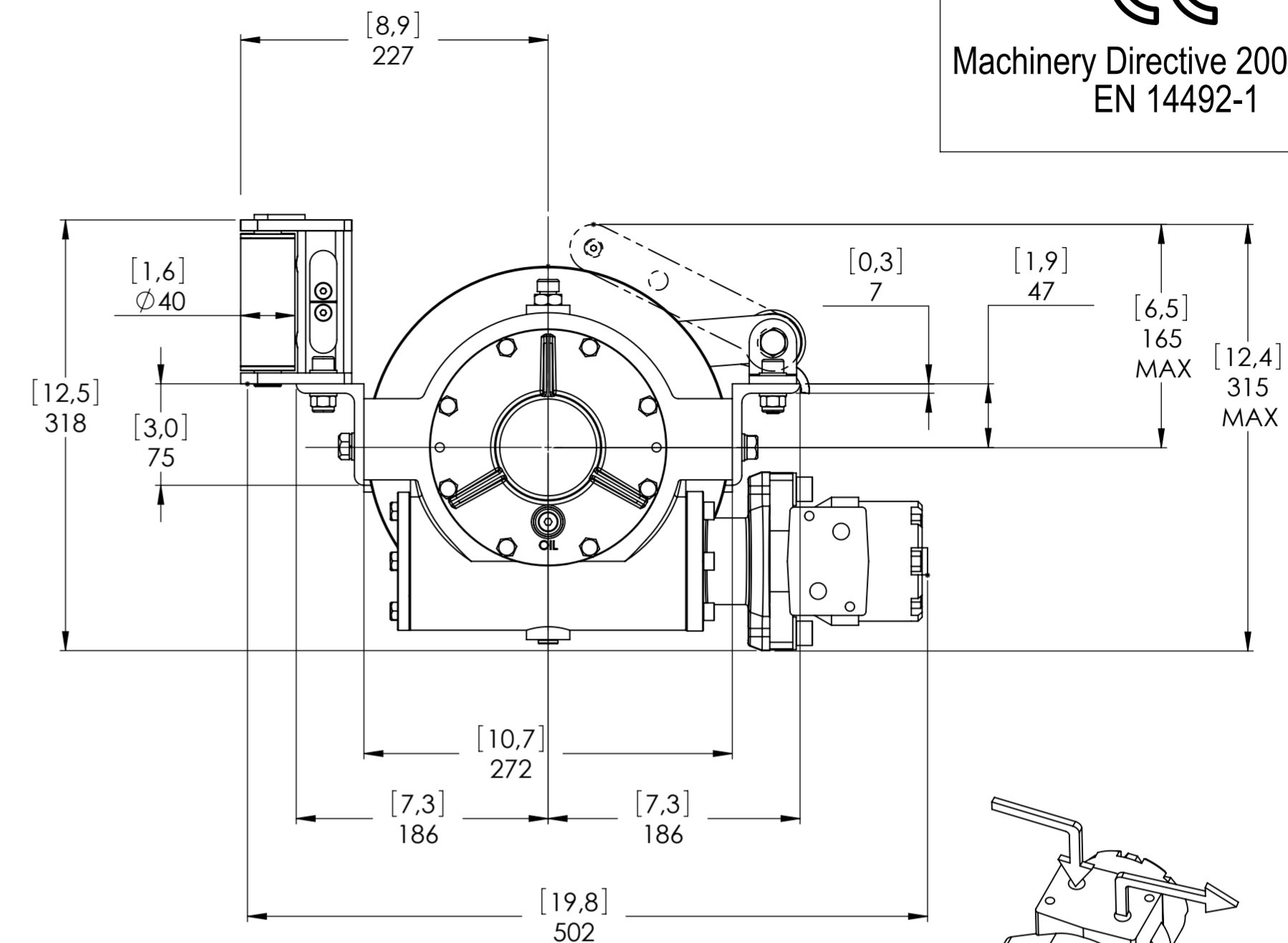
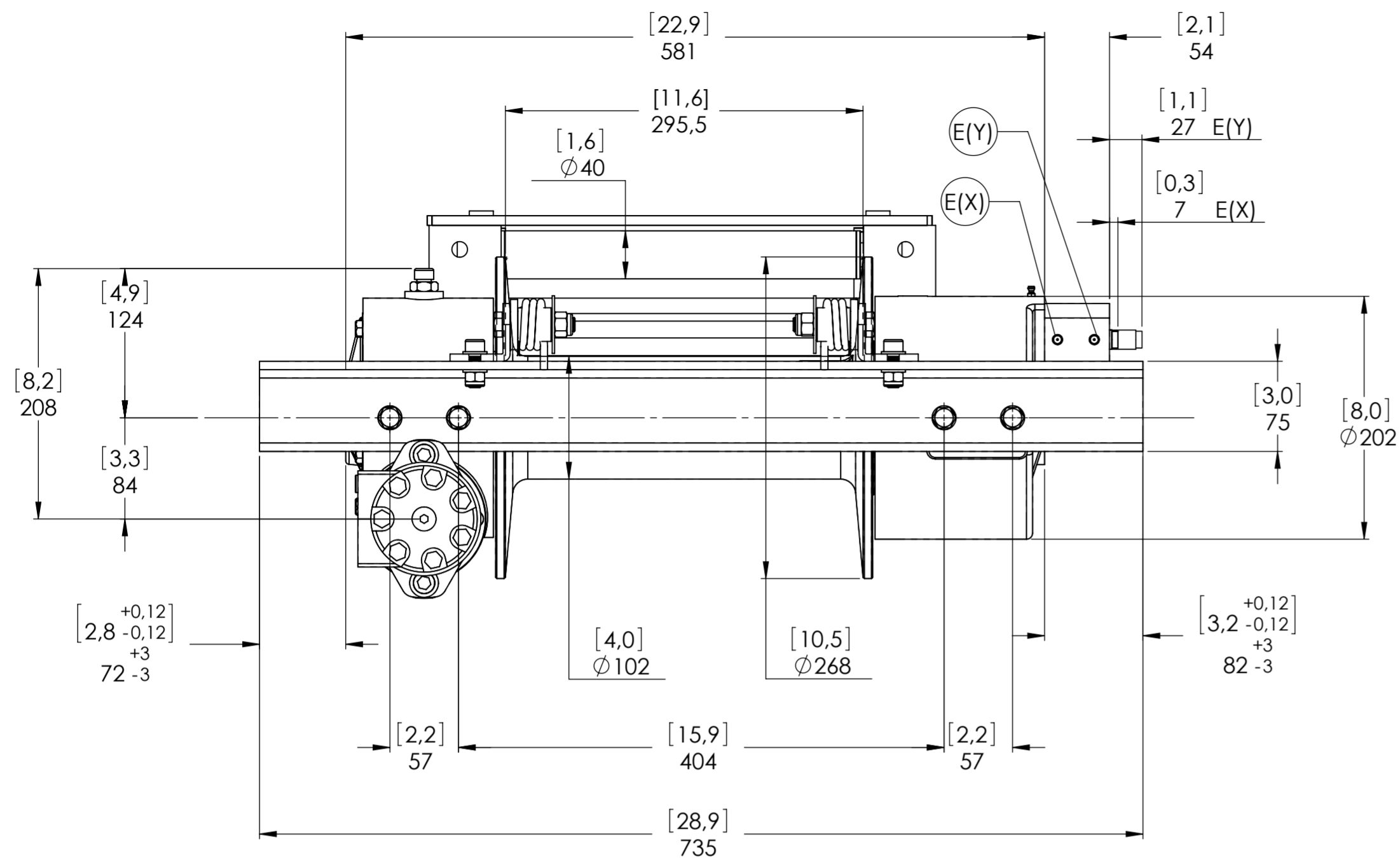

CONNECTIONS	
A	1/2" G
B	1/2" G
C	-----
E (X) DISENGAGED	1/8" G
E (Y) ENGAGED	1/8" G

PLUGS	
1.Fill	3/8" G
2.Level	1/4" G
3.Drain	3/8" G

SCALE 1:4

WEIGHTS	
Winch (without oil)	58 Kgs.
Roller fairlead	----
Heavy-duty roller fairlead	9,6 Kgs.
Rope tensioner	2,2 Kgs.

CODE RCH52K160AGRP

WINCH MODEL	RCH	WINCH GROUP	WORM GEAR
Pulling capacity (Kgs.)	5250	Date	Modification
Max.Oil flow	60 Lt./Min.		
Speed Line - first layer	4,3 Mt./Min.		
Speed Line - top layer	7,6 Mt./Min.		

DANGEROUS: Do not use winch to lift support or transport personnel.

Gear ratio	29:1
Orbital hydr. motor	160 cc
Working pressure	140
Drum size	295,5
Drum clutch	Air-operated

VIME INDUSTRIAL
Funo - Bologna (Italy)
www.vimeindustrial.com
The Quality is Transparent

VIME Industrial reserves the right to improve its products through changes in designed or materials as it may seem desirable without notice. DATE 12/05/2010

1.4.15 RCH 5250 WINCH TECHNICAL DATA

RATIO	WIRE ROPE SIZE [MM]	LAYER	LINE PULL
			[KG]
29:1	11*	1	5.250
		2	4.395
		3	3780
		4	3315
		5	2950

OIL SUPPLY [LT/MIN]	DRUM REVOLUTION [RPM]	LINE SPEED [MT/MIN]				
		1	2	3	4	5
30	7,3	1,8	2,2	2,6	2,9	3,3
40	9,7	2,8	3,4	4,0	4,5	5,1
60	14,9	4,3	5,1	5,9	6,8	7,6

WIRE ROPE MIN. BREAKING LOAD EN 14492-1 [KGS.]	10.500
--	--------

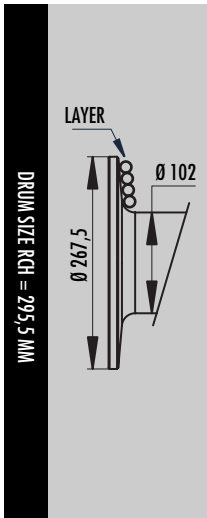

LAYER	DRUM DIAMETER		WIRE ROPE ON LAYER [MT]		WIRE ROPE QUANTITY [MT]	
	Ø MM	-	11 MM	00 MM	11 MM	00 MM
8	267	-	21,7	-	123,5	-
7	245	-	19,9	-	101,8	-
6	223	-	18,1	-	81,9	-
5	201	-	16,3	-	63,8	-
4	179	-	14,5	-	47,5	-
3	157	-	12,8	-	32,9	-
2	135	-	11,0	-	20,2	-
1	113	-	9,2	-	9,2	-
0	102	-	-	-	-	-

WIRE ROPE CAPACITY [MT]		MAX. WIRE ROPE CAPACITY EN 14492-1 [MT]		MAX. WIRE ROPE CAPACITY [MT]	
11 MM	00 MM	11 MM	00 MM	11 MM	00 MM
30	00	81**	00	123	00

DESCRIPTION	WEIGHTS
	[KG]
WINCH (WITHOUT CABLE)	58
ACCESSORY : ROLLER FAIRLEAD	9,6
ACCESSORY : CABLE TENSIONER	2,2

NOTES

Specifications are subject to change without notification and without incurring obligation. Specifications in this publication are theoretical and may vary depending on hydraulic system, environment, etc.

NOTES

*Wire rope size must be respected. Recommended wire rope min. tensile strength 2160 N/mm².
Wire rope minimum breaking load must be at least double of winch max. pulling capacity.

** Max. wire rope capacity according with EN 14492-1.

1.4.16 RCH 5250 WINCH PERFORMANCE CHARTS AT THE 1ST LAYER

LINE PULL-FIRST LAYER [KG]

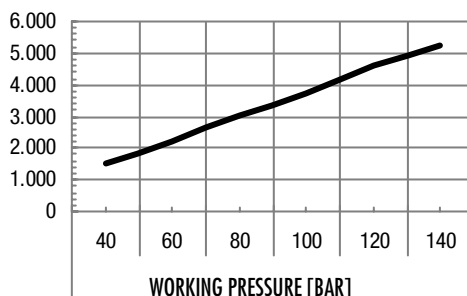

LINE SPEED [MT/MIN]

