

Machinery Directive 2006/42/CE  
EN 14492-1

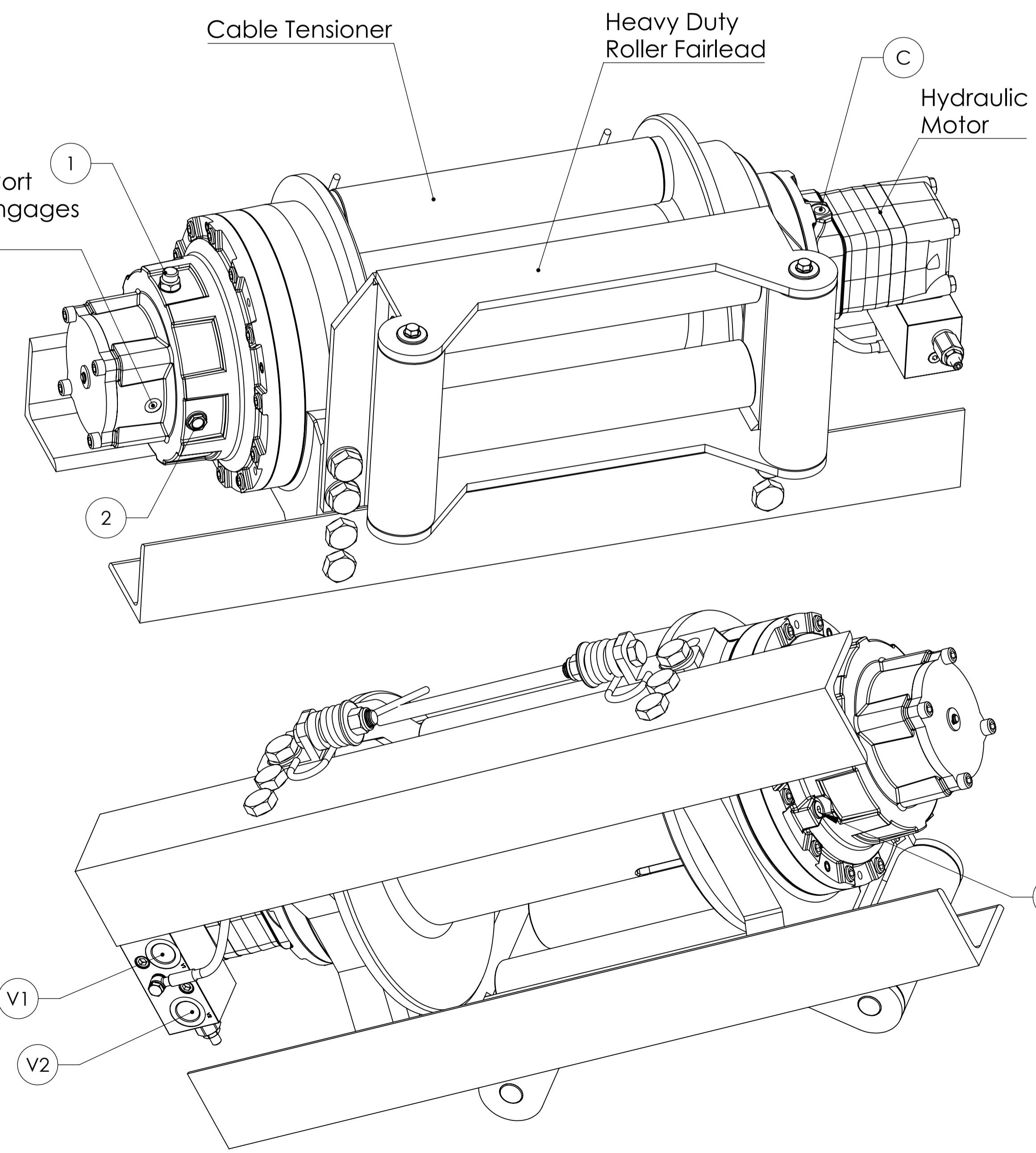

OVERCENTER VALVE POSITION\*

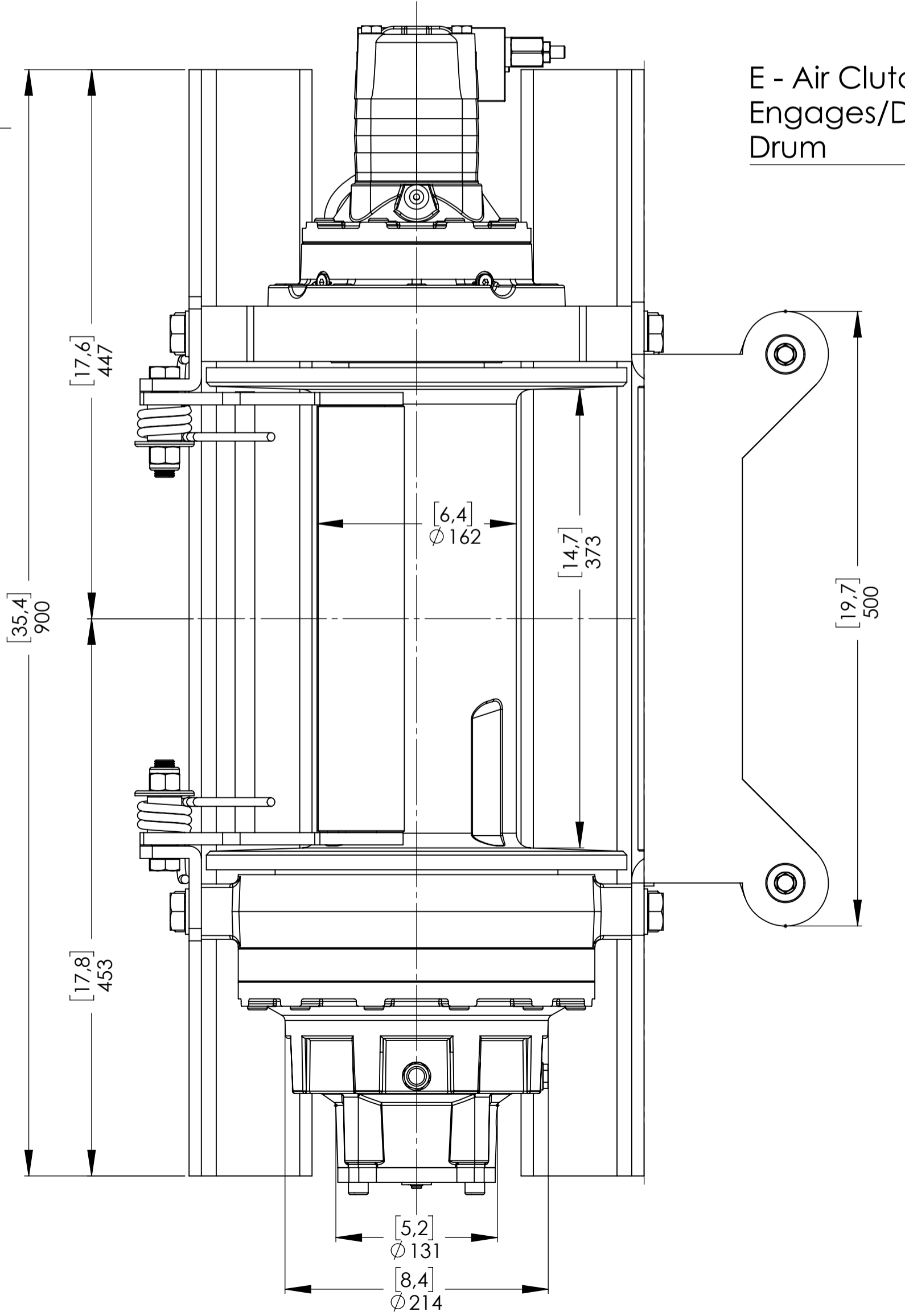
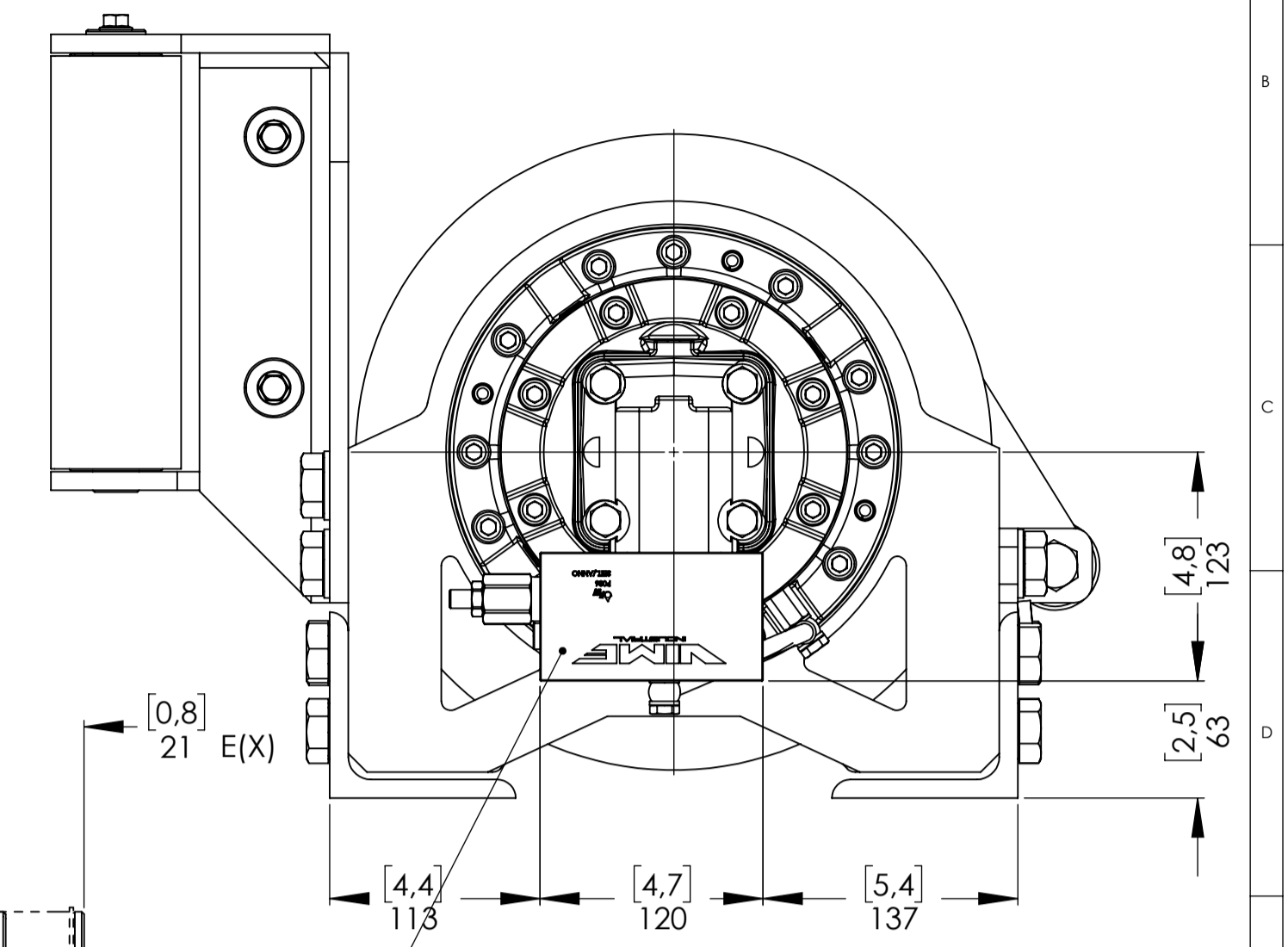
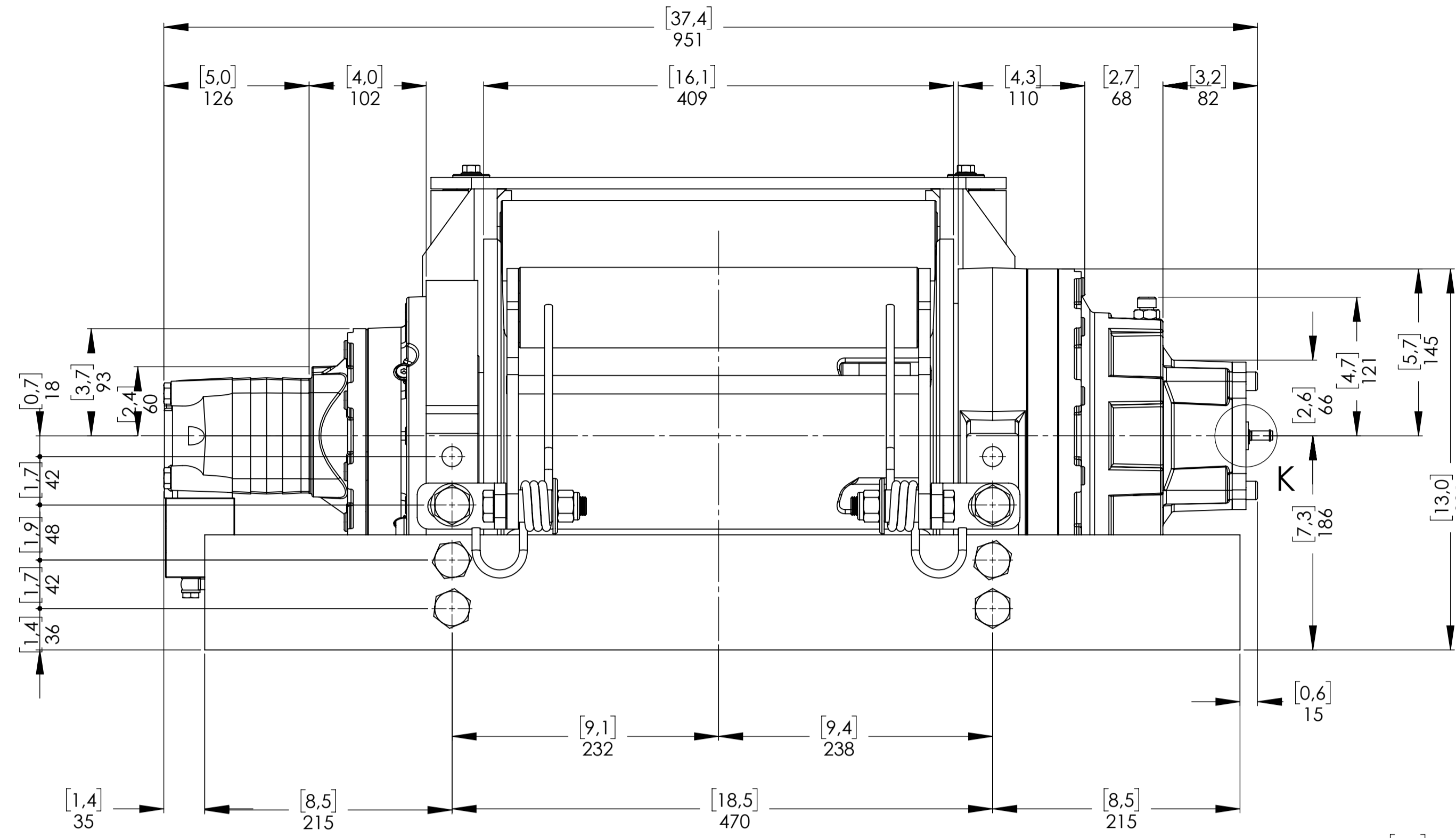
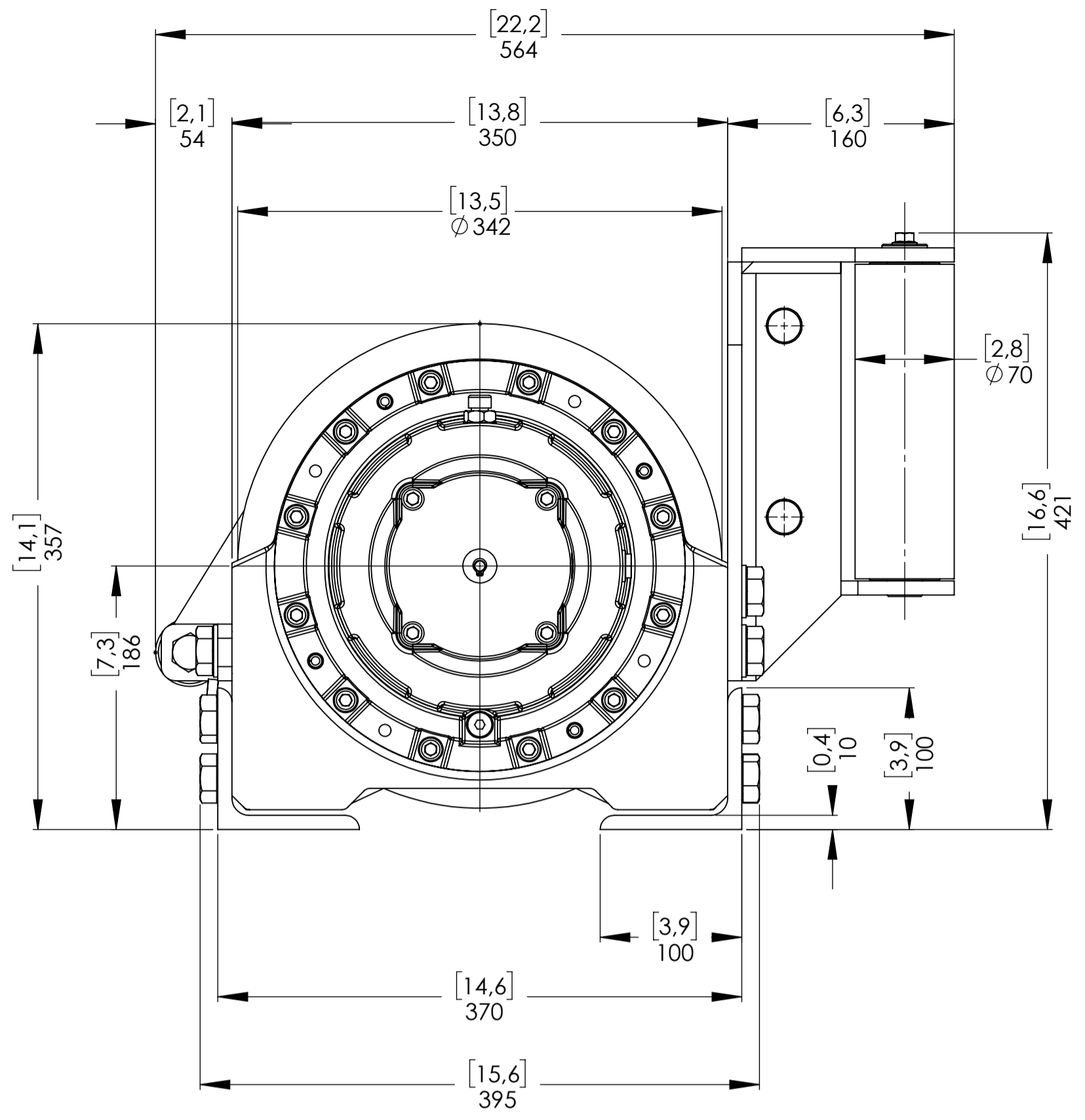
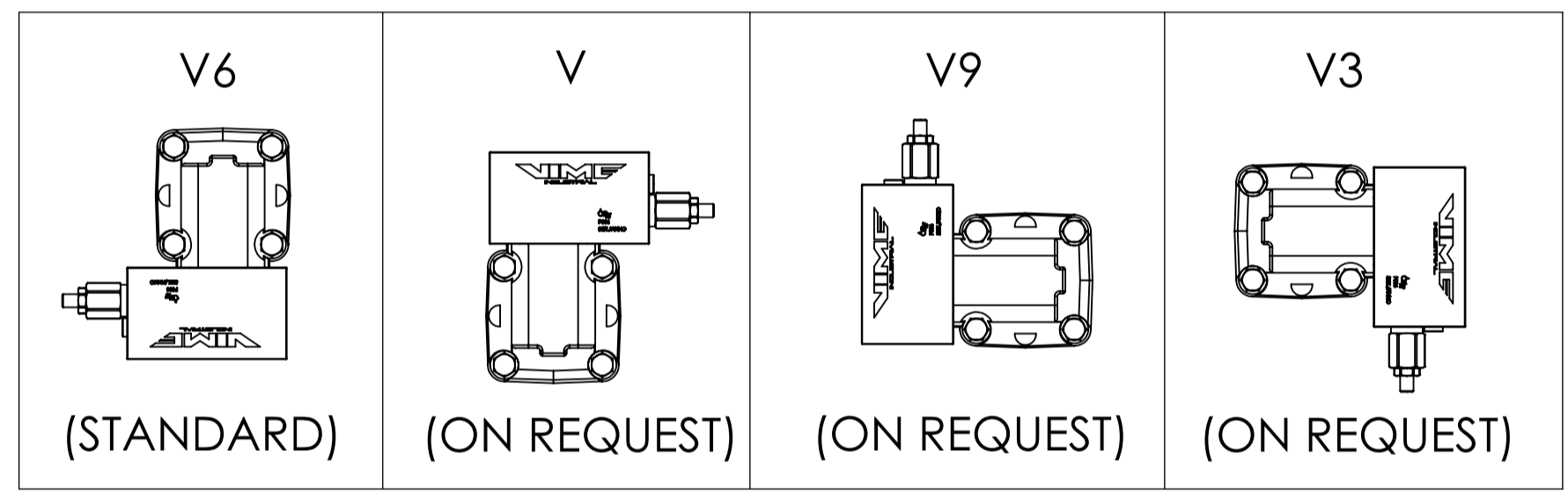

WINCH ORDERING CODE	AIR CLUTCH (STANDARD)	MANUAL CLUTCH (ON REQUEST)	HEAVY DUTY ROLLER FAIRLEAD (ON REQUEST)	CABLE TENSIONER (ON REQUEST)	OVER CENTER VALVE POSITION* (STANDARD V6)
EPHLFN125U20EAV6	X				X
EPHLFN125U20EAPV6	X			X	X
EPHLFN125U20EAGV6	X		X		X
EPHLFN125U20EAGPV6	X		X	X	X
EPHLFN125U20EV6		X			X
EPHLFN125U20EPV6		X		X	X
EPHLFN125U20EGV6		X	X		X
EPHLFN125U20EGPV6		X	X	X	X

\*AT THE MOMENT OF ORDER IS POSSIBLE REQUEST THE OVERCENTER VALVE PORTS ORIENTED ACCORDING TO THE LAY OUT ABOVE. IF NOT SPECIFIED, THE WINCH WILL BE SUPPLIED WITH THE OVERCENTER VALVE PORTS ORIENTED AS PER OUR STANDARD CONFIGURATION V6.

CONNECTIONS	
V1 OUT LET	G 3/4
V2 IN LET	G 3/4
C CASE DRAIN	G 1/4
E (X) DISENGAGED	G 1/8
E (Y) ENGAGED	RETURN SPRING

WINCH MODEL	EPHL 125 FN	WINCH GROUP	PLANETARY GEAR	PLUGS
Pulling capacity	12500 Kg	Date	Modification	1.Fill G 3/8
Max.Oil flow	75 Lt./Min.			2.Level G 3/8
Speed Line - first layer	9,2 Mt./Min.			3.Drain G 1/4
Speed Line - top layer	14,5 Mt./Min.	<b>DANGEROUS:</b> Do not use winch to lift support or transport personnel.		SCALE 1:3.5
 Funo - Bologna (Italy) www.vimeindustrial.com <b>The Quality is Transparent</b>		Gear ratio	1/22,69	WEIGHTS
		Orbital hydr. motor	200 cc	Winch (without oil) 200 Kg
		Working pressure	200 bar	Heavy-duty
		Drum size	373 mm	Roller fairlead 35 Kg
		Drum clutch	Air-operated	Cable tensioner 10 Kg
		VIME Industrial : reserves the right to improve its products through changes in designed or materials as if may seem desirable without notice		COD. EPHLFN125U20EAGPV6
		DATA 19/09/2016		

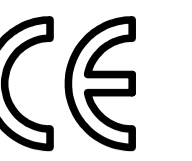

Machinery Directive 2006/42/CE  
EN 14492-1

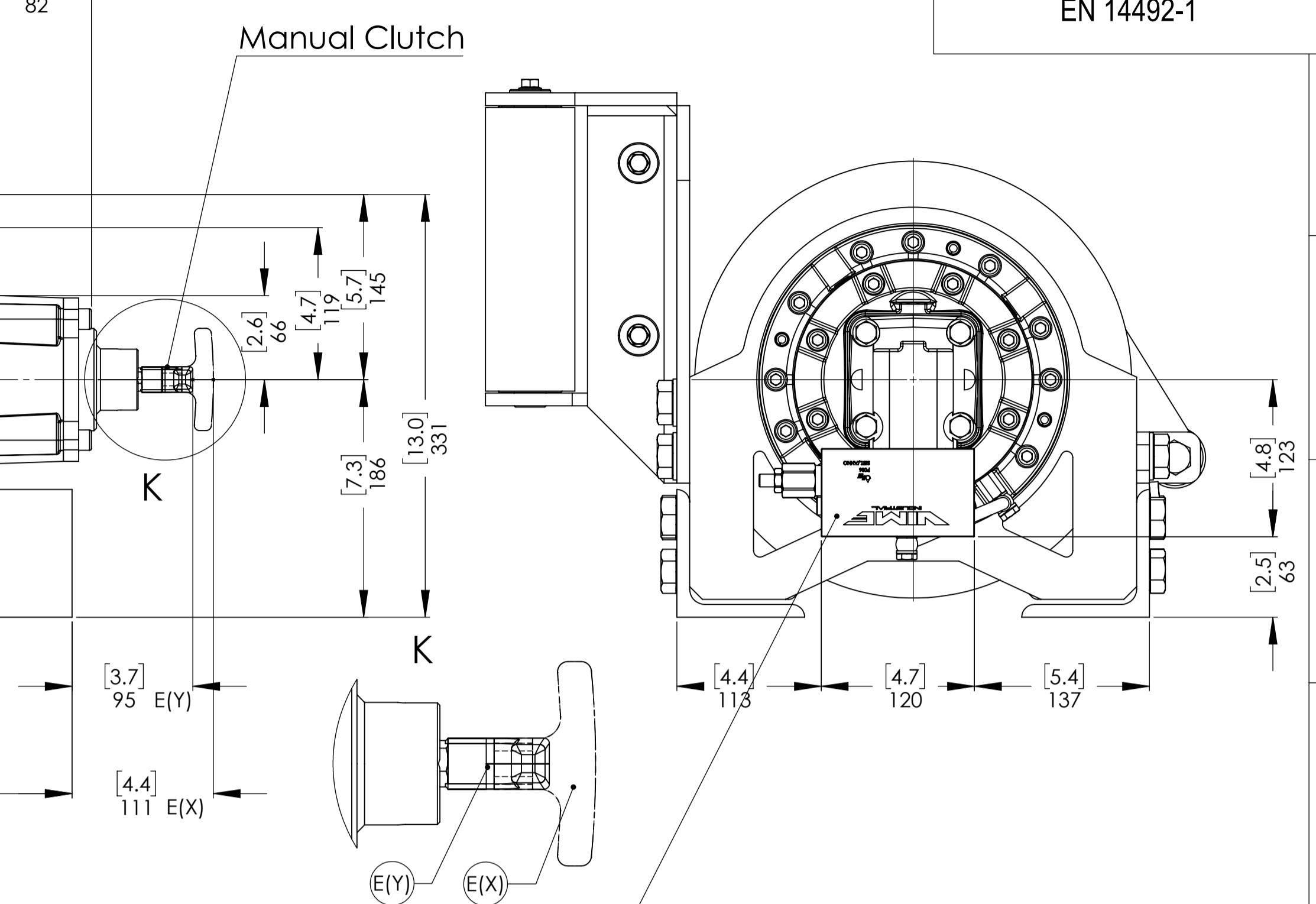
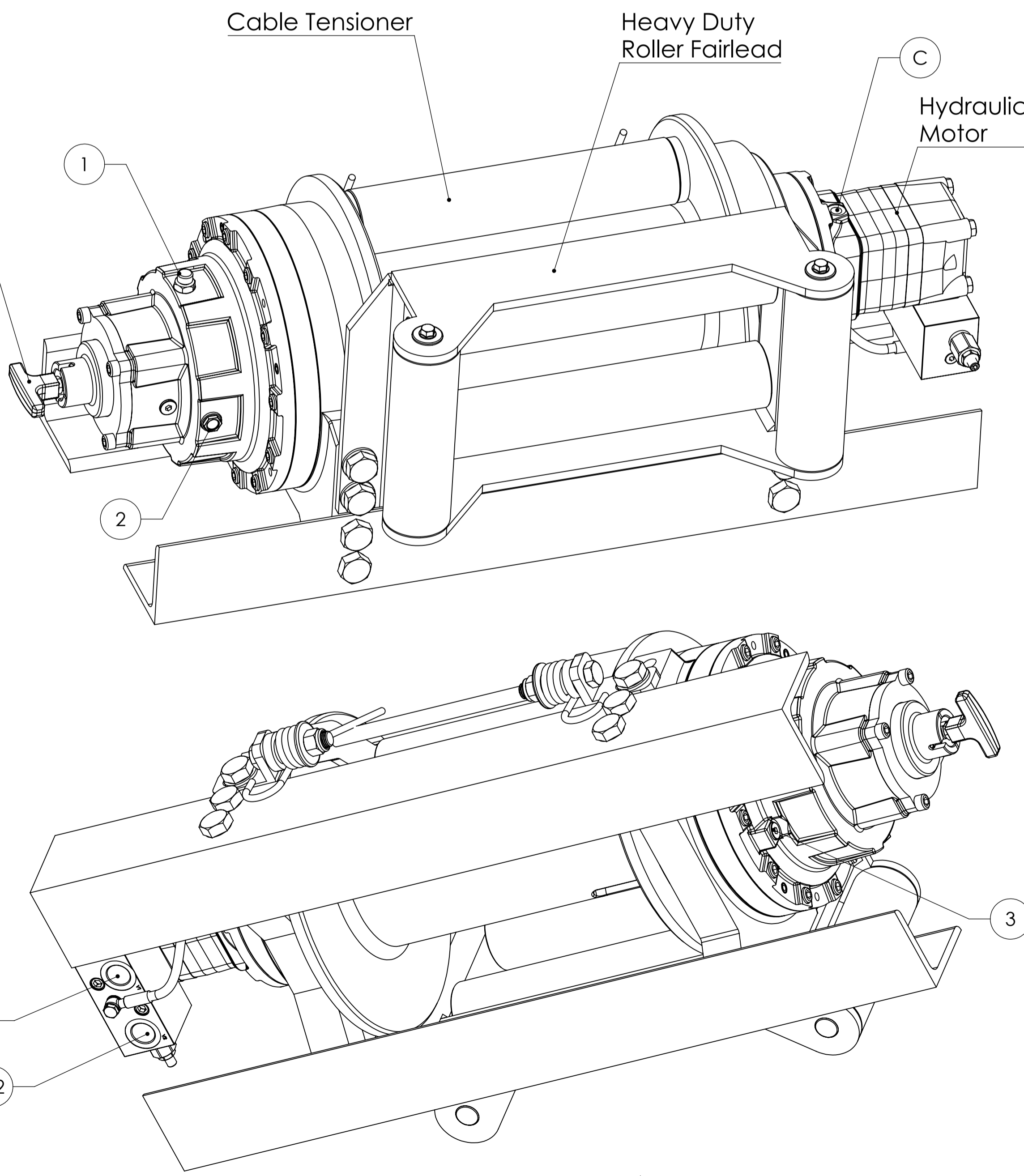
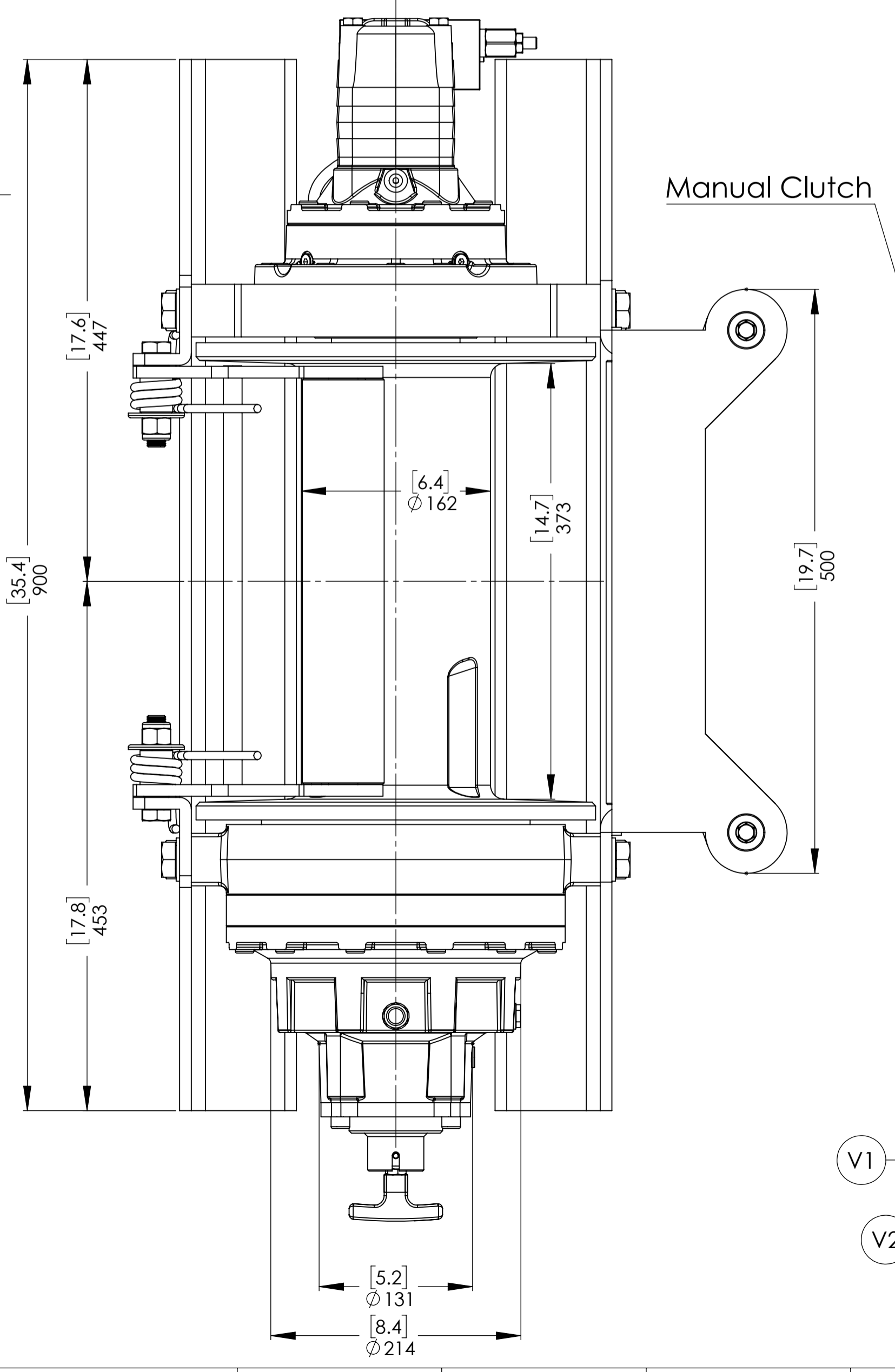
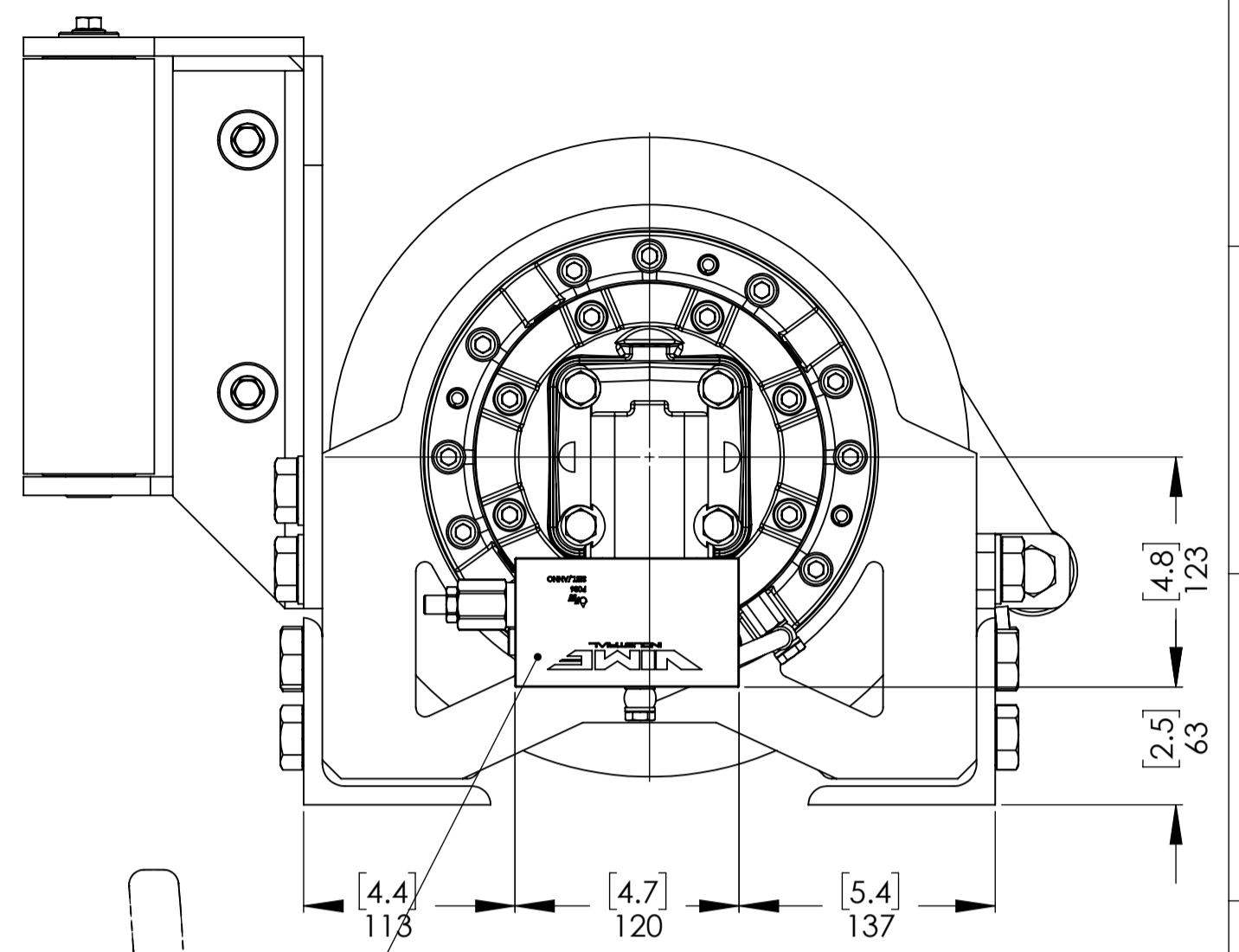
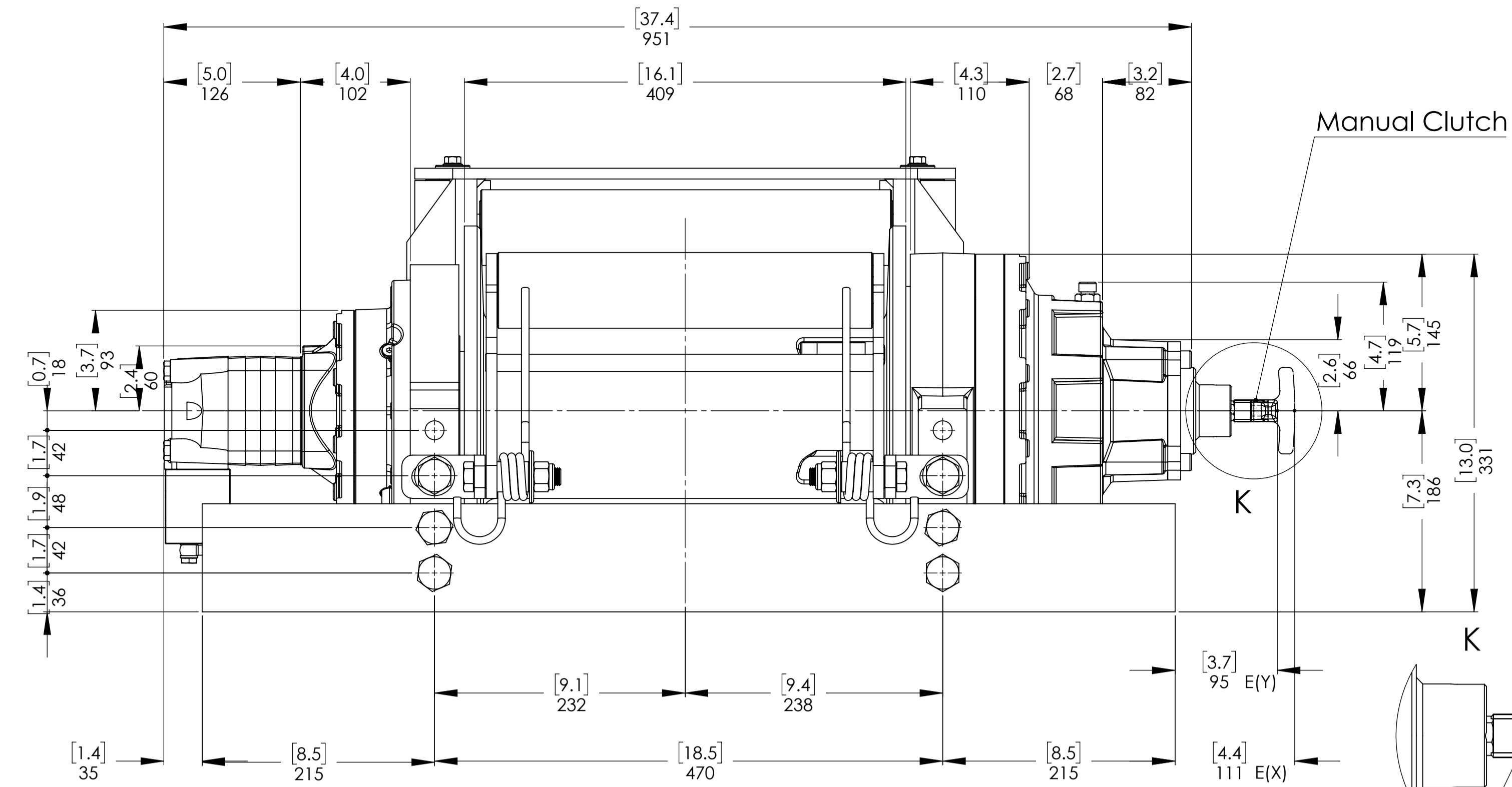
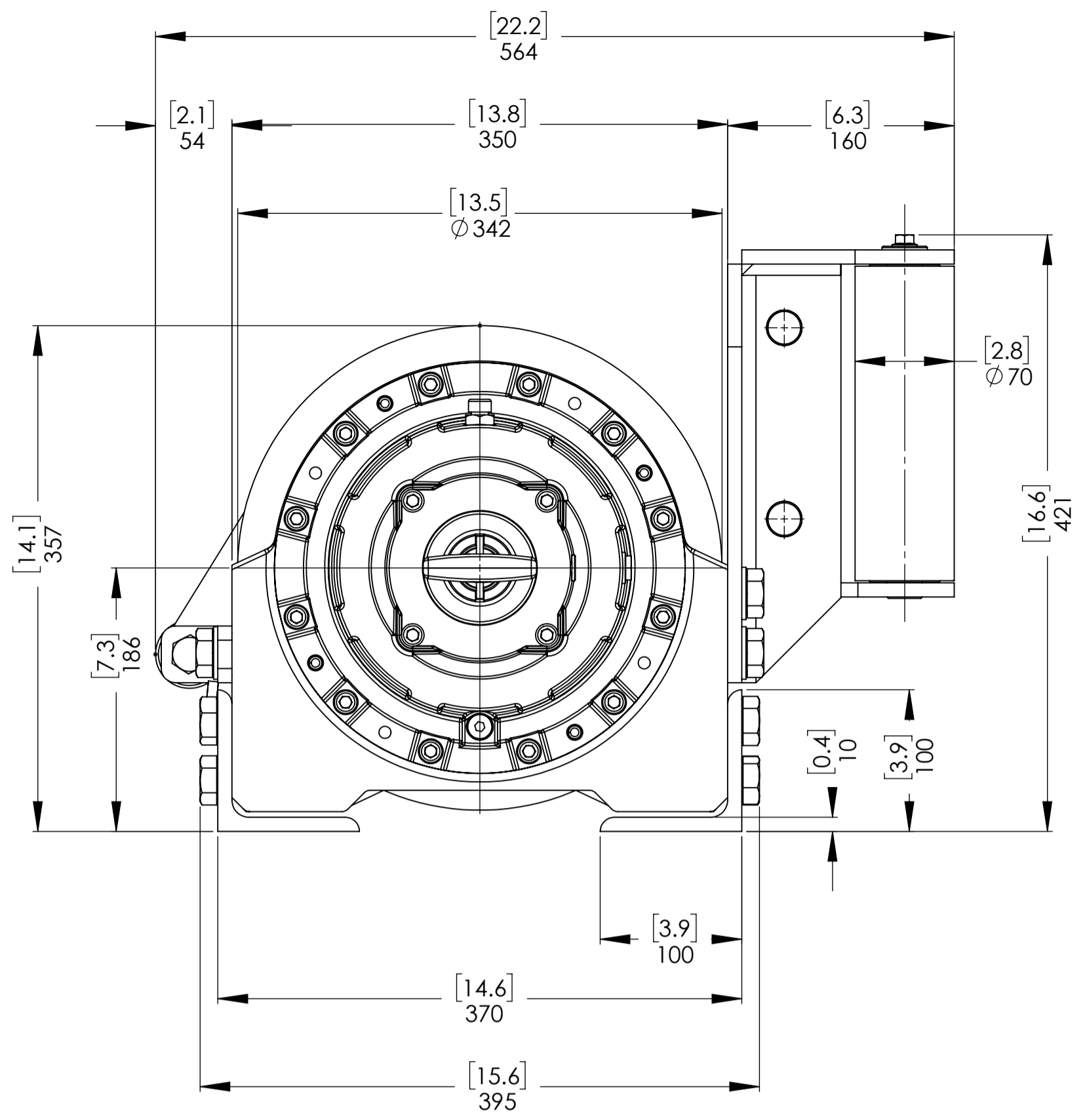

OVERCENTER VALVE POSITION\*

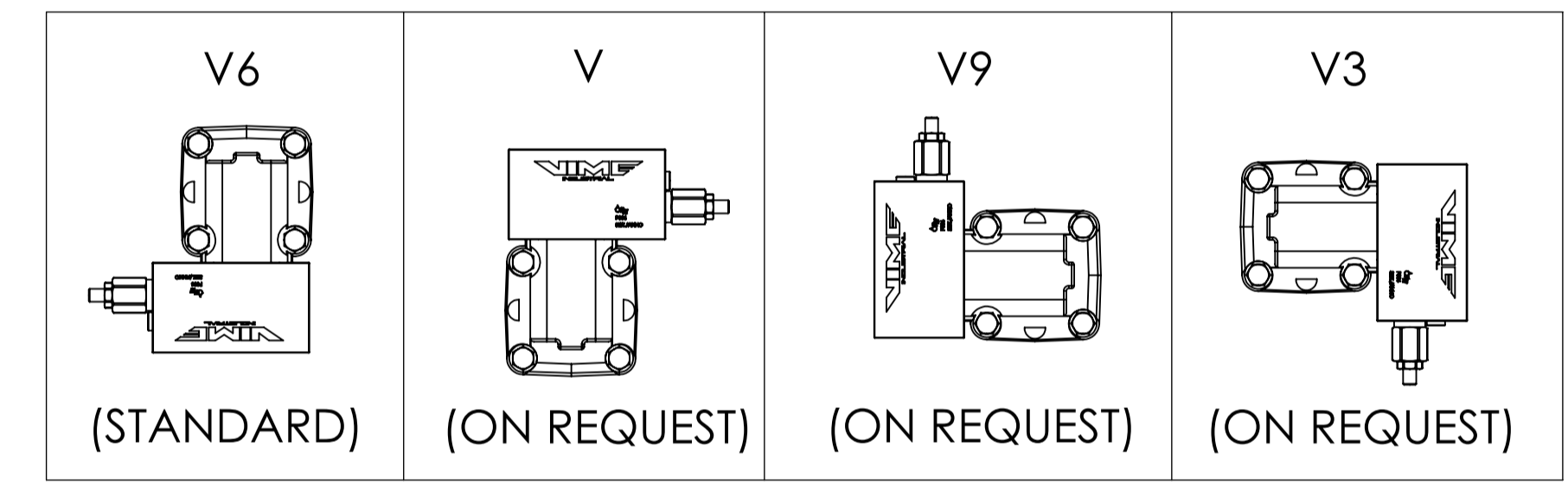

WINCH ORDERING CODE	AIR CLUTCH (STANDARD)	MANUAL CLUTCH (ON REQUEST)	HEAVY DUTY ROLLER FAIRLEAD (ON REQUEST)	CABLE TENSIONER (ON REQUEST)	OVER CENTER VALVE POSITION* (STANDARD V6)
EPHLFN125U20EAV6	X				X
EPHLFN125U20EAPV6	X			X	X
EPHLFN125U20EAGV6	X		X		X
EPHLFN125U20EAGPV6	X		X	X	X
EPHLFN125U20EV6		X			X
EPHLFN125U20EPV6		X		X	X
EPHLFN125U20EGV6		X	X		X
EPHLFN125U20EGPV6		X	X	X	X

\*AT THE MOMENT OF ORDER IS POSSIBLE REQUEST THE OVERCENTER VALVE PORTS ORIENTED ACCORDING TO THE LAY OUT ABOVE. IF NOT SPECIFIED, THE WINCH WILL BE SUPPLIED WITH THE OVERCENTER VALVE PORTS ORIENTED AS PER OUR STANDARD CONFIGURATION V6.

CONNECTIONS	
V1 OUT LET	G 3/4
V2 IN LET	G 3/4
C CASE DRAIN	G 1/4
E (X) DISENGAGED	-----
E (Y) ENGAGED	-----

WINCH MODEL	EPHL 125 FN	WINCH GROUP	PLANETARY GEAR	PLUGS
Pulling capacity	12500 Kg	Date	Modification	1.Fill G 3/8
Max.Oil flow	75 Lt./Min.			2.Level G 3/8
Speed Line - first layer	9,2 Mt./Min.			3.Drain G 1/4
Speed Line - top layer	14,5 Mt./Min.	<b>DANGEROUS:</b> Do not use winch to lift support or transport personnel.		SCALE 1:3.5
		Gear ratio	1/22,69	WEIGHTS
		Orbital hydr. motor	200 cc	Winch (without oil) 200 Kg
		Working pressure	200 bar	Heavy-duty
		Drum size	373 mm	Roller fairlead 35 Kg
		Drum clutch	Manual	Cable tensioner 10 Kg
 Funo - Bologna (Italy) www.vimeindustrial.com <b>The Quality is Transparent</b>		VIME Industrial reserves the right to improve its products through changes in designed or materials as it may seem desirable without notice.		DATA 19/09/2016 COD. EPHLFN125U20EGPV6

### 1.4.13 EPHL 125 FN CE TECHNICAL DATA

FEATURES EPHL 125 FN CE (200 cc.)	
LINE PULL FIRST LAYER	12.500 KGF
LINE SPEED FIRST LAYER	9,2 MT/MIN.
MAX. WORKING PRESSURE	200 BAR
MAX. OIL SUPPLY	75 LT/MIN
MIN. OIL SUPPLY	20 LT/MIN
WIRE ROPE SIZE (EN 14492-1)	*15/18 mm
WIRE ROPE MINIMUM BREAKING ROPE (EN 14492-1)	25.000 KG
MAX. WIRE ROPE CAPACITY (EN 14492-1)	**80/55 MT

LINE SPEED [MT/MIN]							
	OIL SUPPLY [LT/MIN]	DRUM REVOLUTION [RPM]	LINE SPEED PER LAYER [MT/MIN]				
			1	2	3	4	5
ROPE 15 MM	40	8,1	4,5	5,1	5,9	6,7	7,3
	60	12,6	7,1	8,1	9,4	10,6	11,6
	75	16	9,1	10,4	12,0	13,5	15,0
ROPE 18 MM	40	8,1	4,6	5,5	6,4	7,3	8,2
	60	12,6	7,2	8,6	10	11,4	12,8
	75	16	9,2	10,9	12,7	14,5	16,3

WIRE ROPE QUANTITY ON LAYER (DRUM LENGTH EPHL FN= 373 MM)							
LAYER	LAYER	DRUM DIAMETER [MM]		WIRE ROPE ON LAYER [MT]		WIRE ROPE QUANTITY [MT]	
		15 MM	18 MM	15 MM	18 MM	15 MM	18 MM
		6	327	-	24,5	-	113,4
5	297	324	22,3	20,1	88,9	78,1	
4	267	288	20,0	17,8	66,6	58	
3	237	252	17,8	15,6	46,6	40,1	
2	207	216	15,5	13,4	28,8	24,5	
1	177	180	13,3	11,2	13,3	11,2	
0	162	162	-	-	-	-	

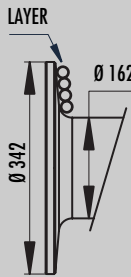

LINE PULL [KGF]		
RATIO	LAYER	LINE PULL [KGF]
22,69:1	1	12.500
	2	10.680
	3	9.330
	4	8.280
	5	7.440
22,69:1	1	12.500
	2	10.410
	3	8.920
	4	7.810
	5	6.940

**NOTE** 

Specifications are subject to change without notification and without incurring obligation. Specifications in this publication are theoretical and may vary depending on hydraulic system, environment, etc.

\*Wire rope size must be respected. Recommended wire rope min. tensile strength 2160 N/mm<sup>2</sup>. Wire rope minimum breaking load must be at least double of winch max. pulling capacity.

\*\* Max. wire rope capacity according with EN 14492-1.

WEIGHT [KG]	
WINCH (WITHOUT CABLE)	200
ACCESSORY : ROLLERFAIRLEAD	35
ACCESSORY : CABLE TENSIONER	10

### 1.4.14 EPHL 125 FN CE WINCH PERFORMANCE CHARTS AT THE 1<sup>ST</sup> LAYER

