

Machinery Directive 2006/42/CE
EN 14492-1

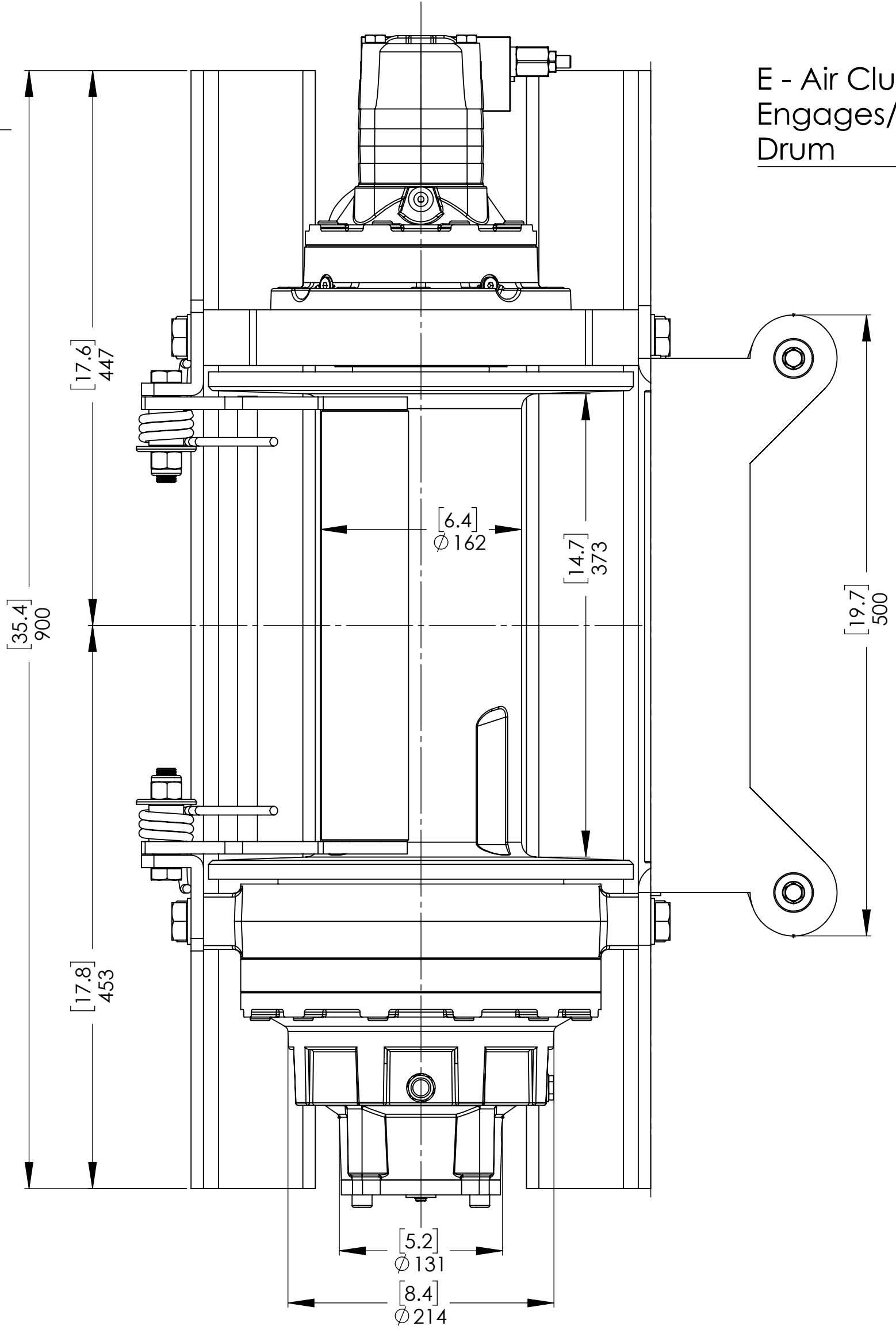

E - Air Clutch Port Engages/Disengages Drum

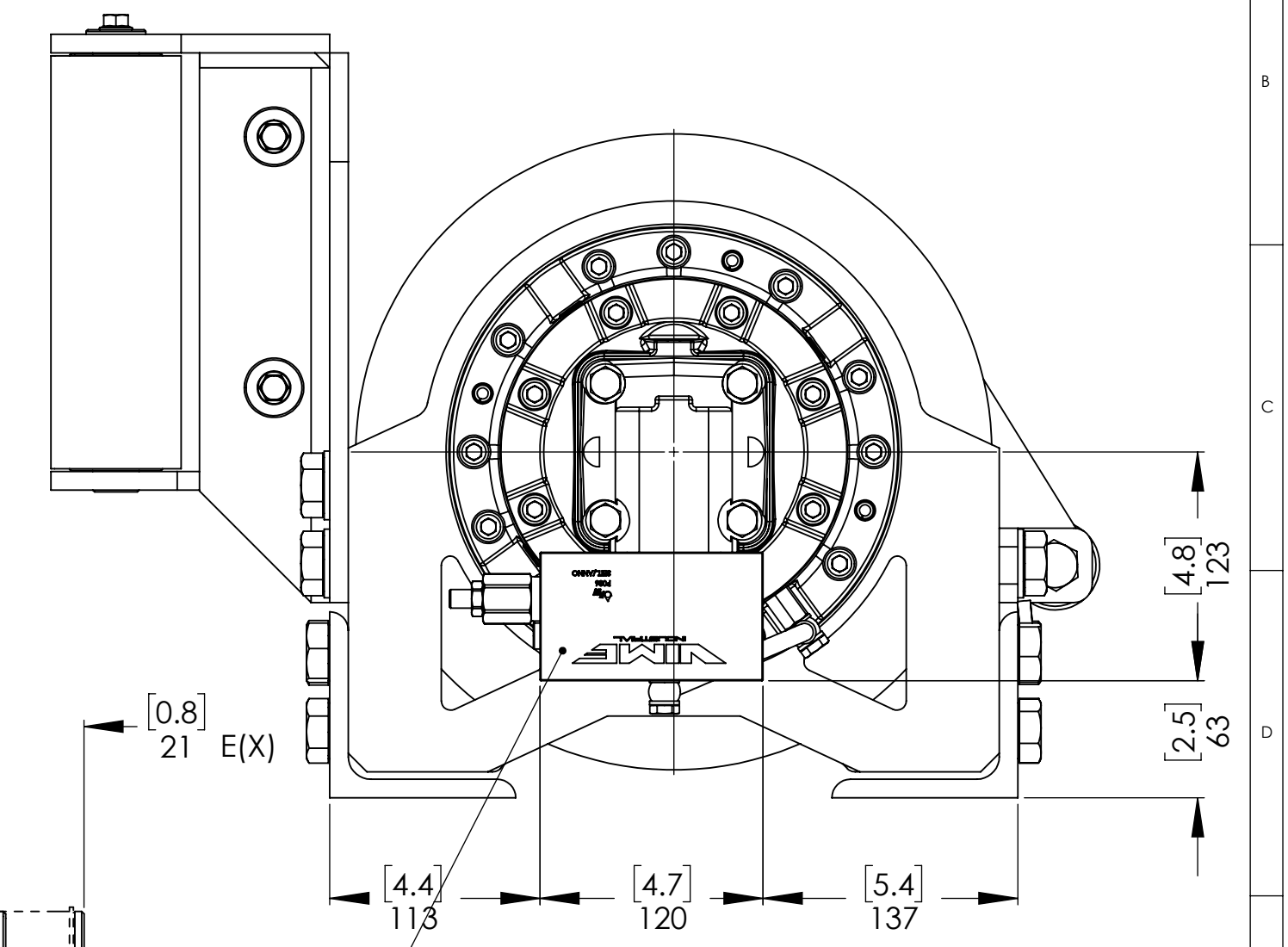
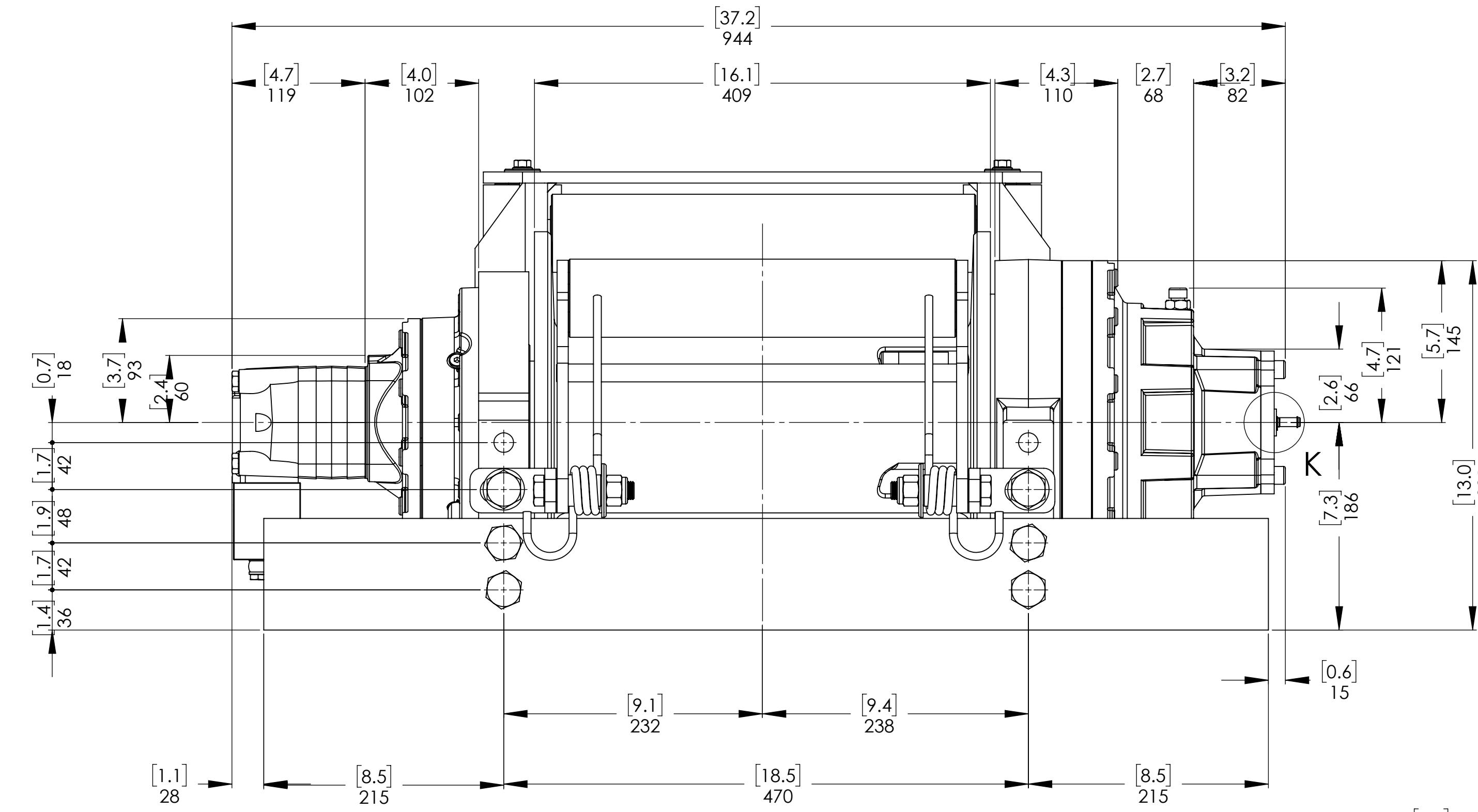
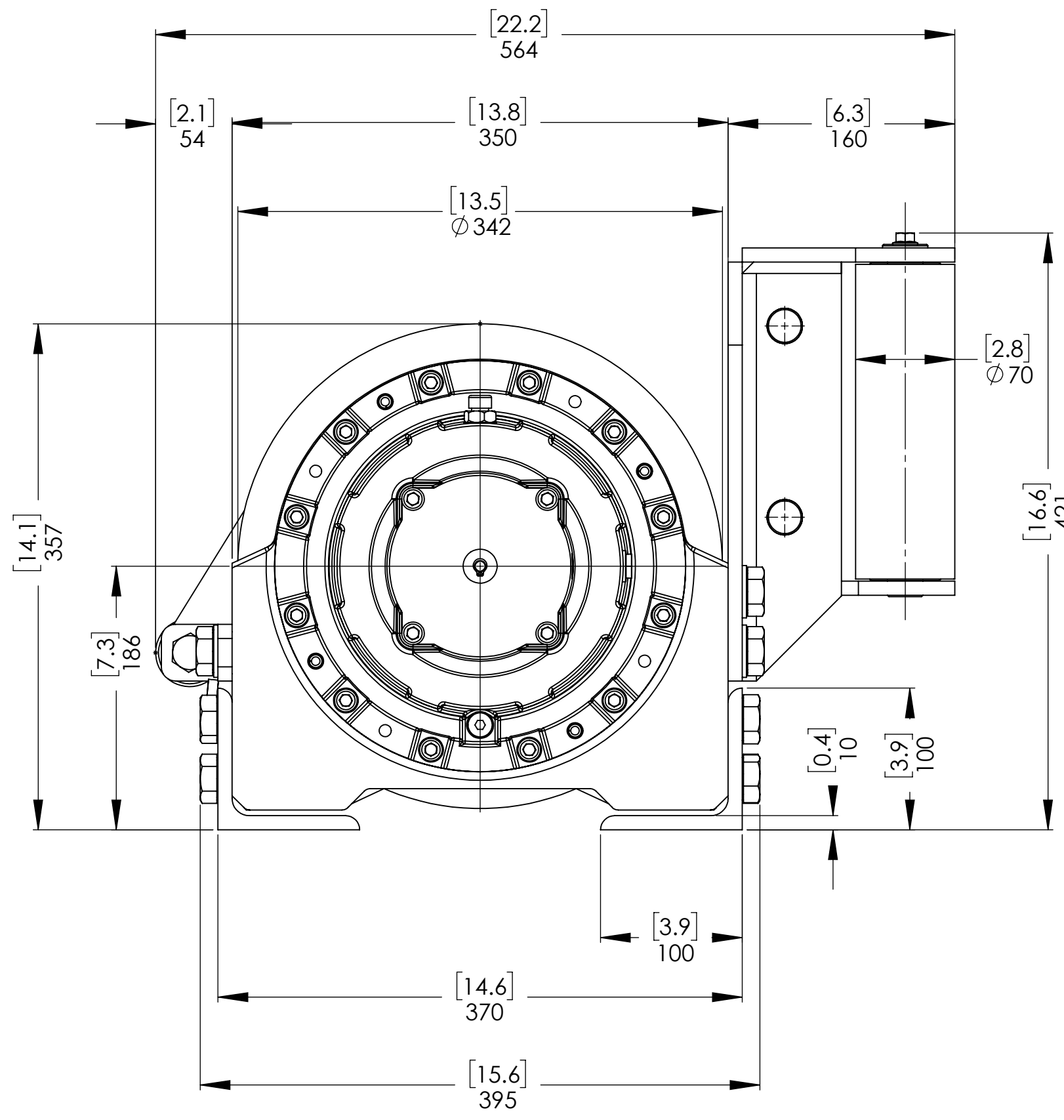
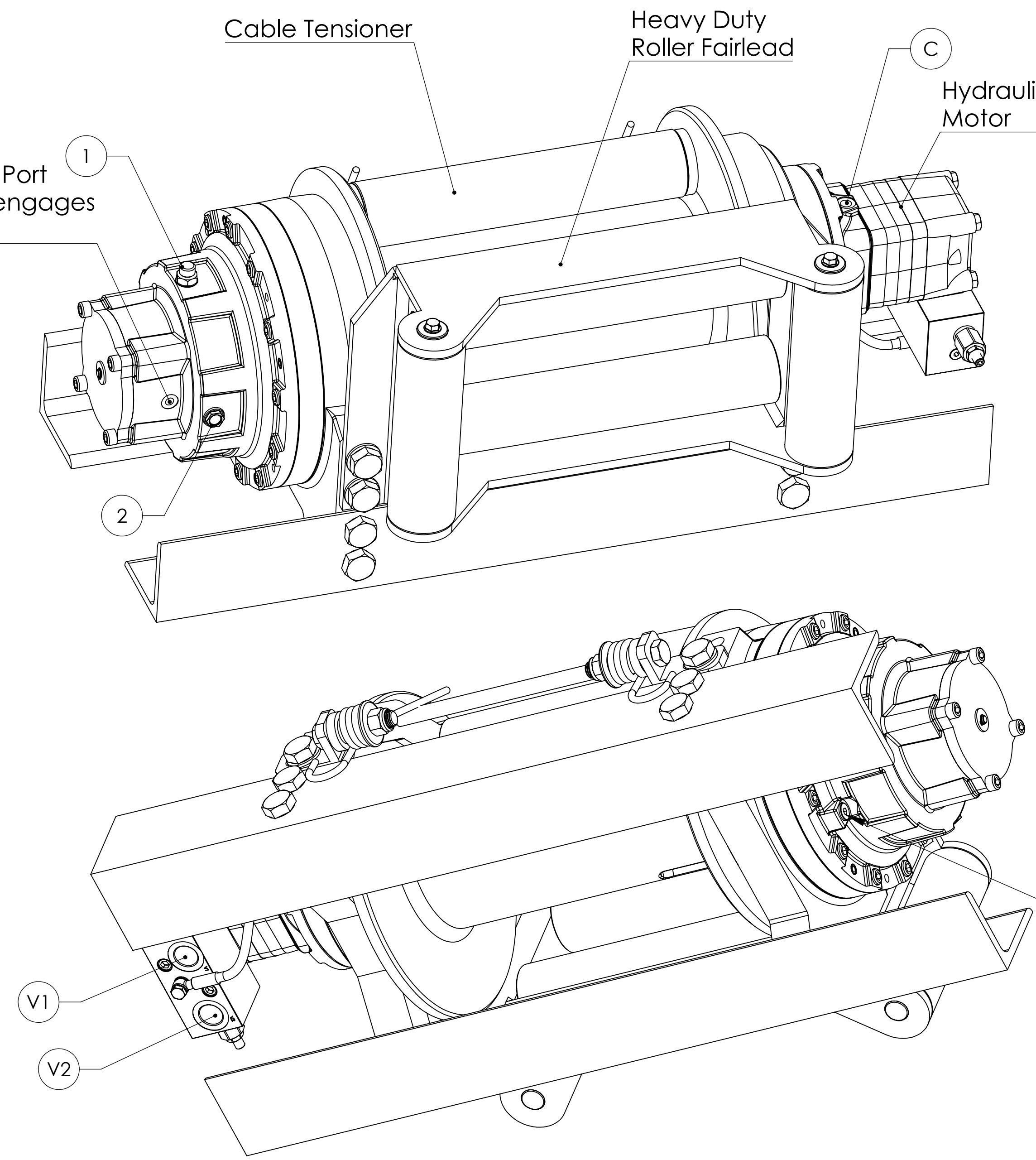

OVERCENTER VALVE POSITION*

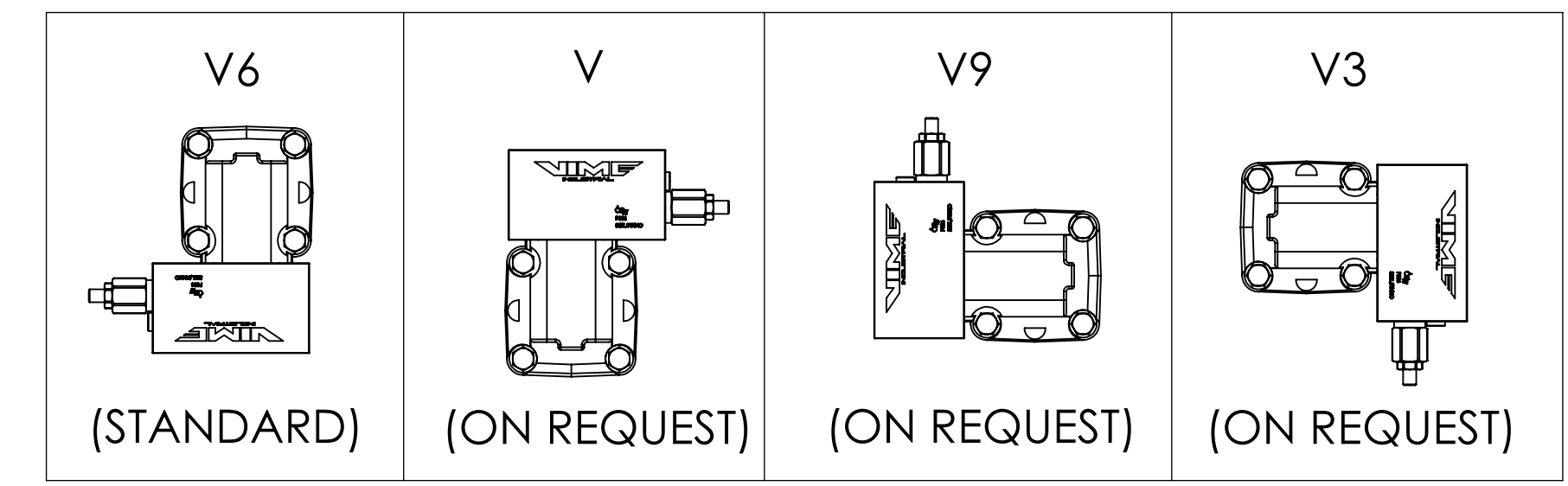

WINCH ORDERING CODE	AIR CLUTCH (STANDARD)	MANUAL CLUTCH (ON REQUEST)	HEAVY DUTY ROLLER FAIRLEAD (ON REQUEST)	CABLE TENSIONER (ON REQUEST)	OVER CENTER VALVE POSITION* (STANDARD V6)
EPHLFN100U16EAV6	X				X
EPHLFN100U16EAPV6	X			X	X
EPHLFN100U16EAGV6	X		X		X
EPHLFN100U16EAGPV6	X		X	X	X
EPHLFN100U16EV6		X			X
EPHLFN100U16EPV6		X		X	X
EPHLFN100U16EGV6		X	X		X
EPHLFN100U16EGPV6		X	X	X	X

*AT THE MOMENT OF ORDER IS POSSIBLE REQUEST THE OVERCENTER VALVE PORTS ORIENTED ACCORDING TO THE LAYOUT ABOVE. IF NOT SPECIFIED, THE WINCH WILL BE SUPPLIED WITH THE OVERCENTER VALVE PORTS ORIENTED AS PER OUR STANDARD CONFIGURATION V6.

CONNECTIONS	
V1 OUT LET	G 3/4
V2 IN LET	G 3/4
C CASE DRAIN	G 1/4
E (X) DISENGAGED	G 1/8
E (Y) ENGAGED	RETURN SPRING

WINCH MODEL	EPHL 100 FN	WINCH GROUP	PLANETARY GEAR	PLUGS
Pulling capacity	10000 Kg	Date	Modification	1.Fill G 3/8
Max.Oil flow	75 Lt./Min.			2.Level G 3/8
Speed Line - first layer	11,1 Mt./Min.			3.Drain G 1/4
Speed Line - top layer	19,2 Mt./Min.	DANGEROUS: Do not use winch to lift support or transport personnel.		SCALE 1:3.5
		Gear ratio	1/22,69	WEIGHTS
		Orbital hydr. motor	160 cc	Winch (without oil) 200 Kg
		Working pressure	200 bar	Heavy-duty Roller fairlead 35 Kg
		Drum size	373 mm	Cable tensioner 10 Kg
		Drum clutch	Air-operated	
 Funo - Bologna (Italy) www.vimeindustrial.com The Quality is Transparent		VIME Industrial reserves the right to improve its products through changes in designed or materials as if may seem desirable without notice.		DATA 19/09/2016 COD. EPHLFN100U16EAGPV6

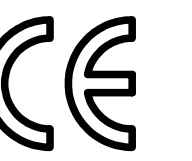

Machinery Directive 2006/42/CE
EN 14492-1

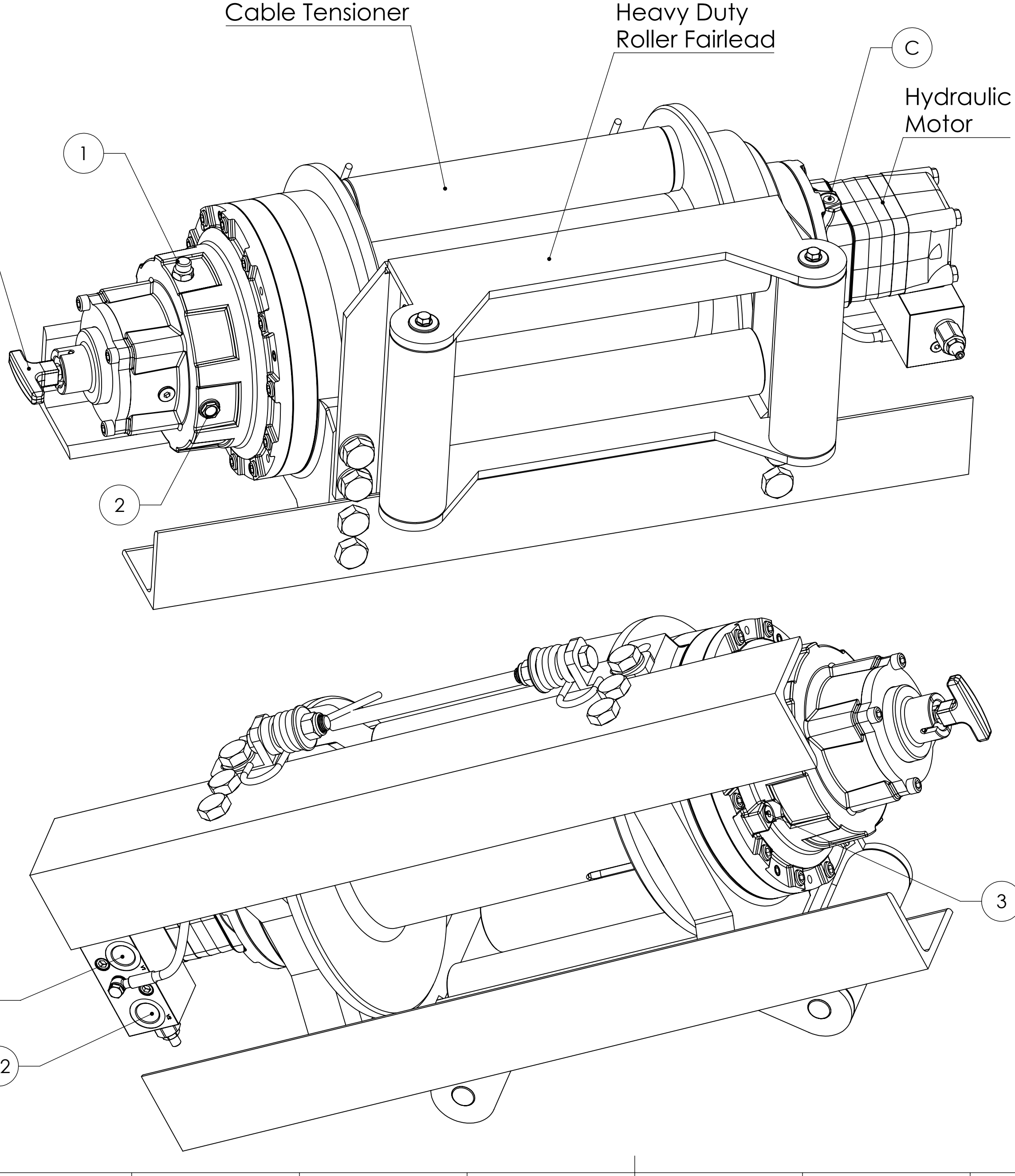
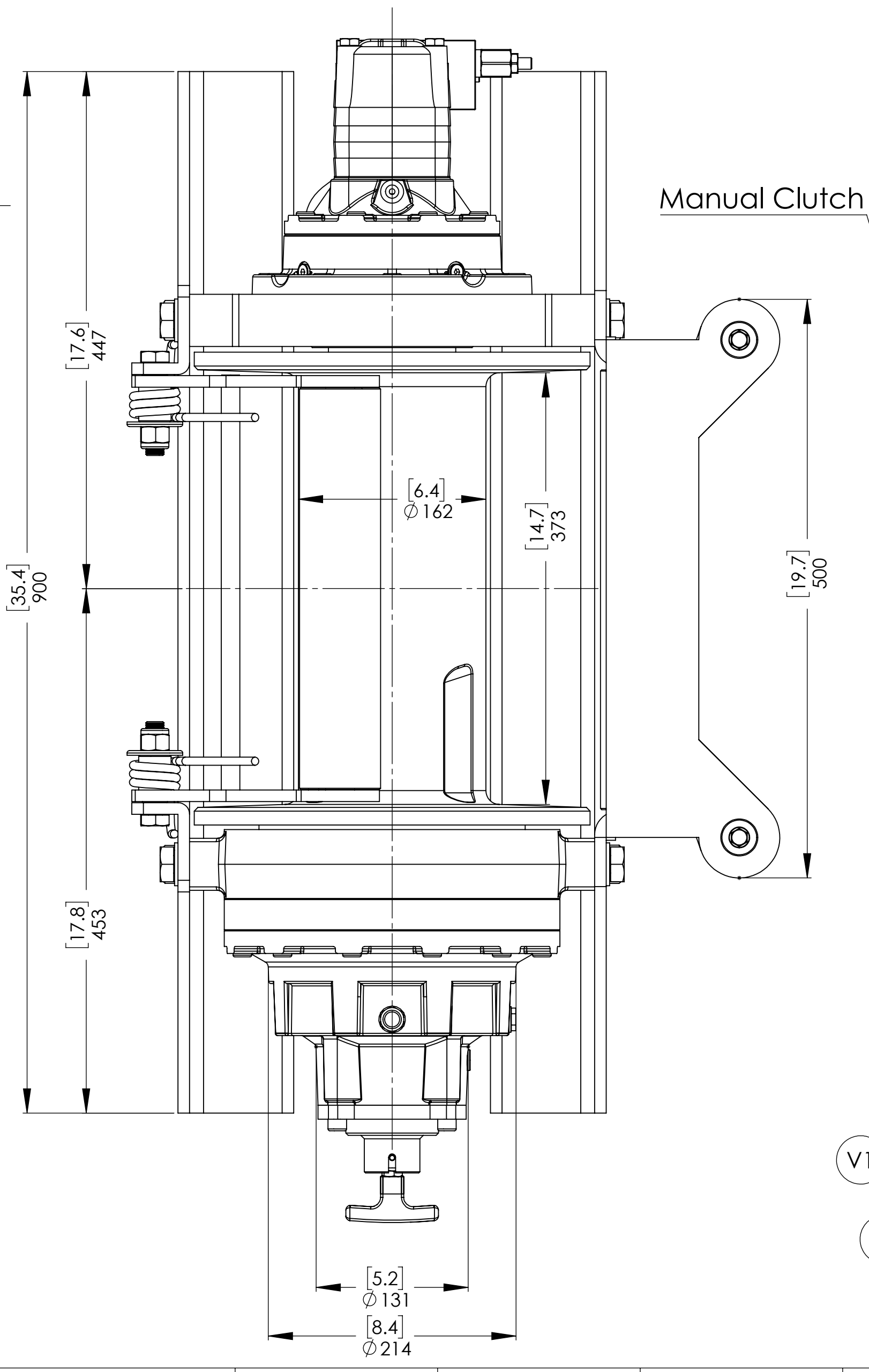
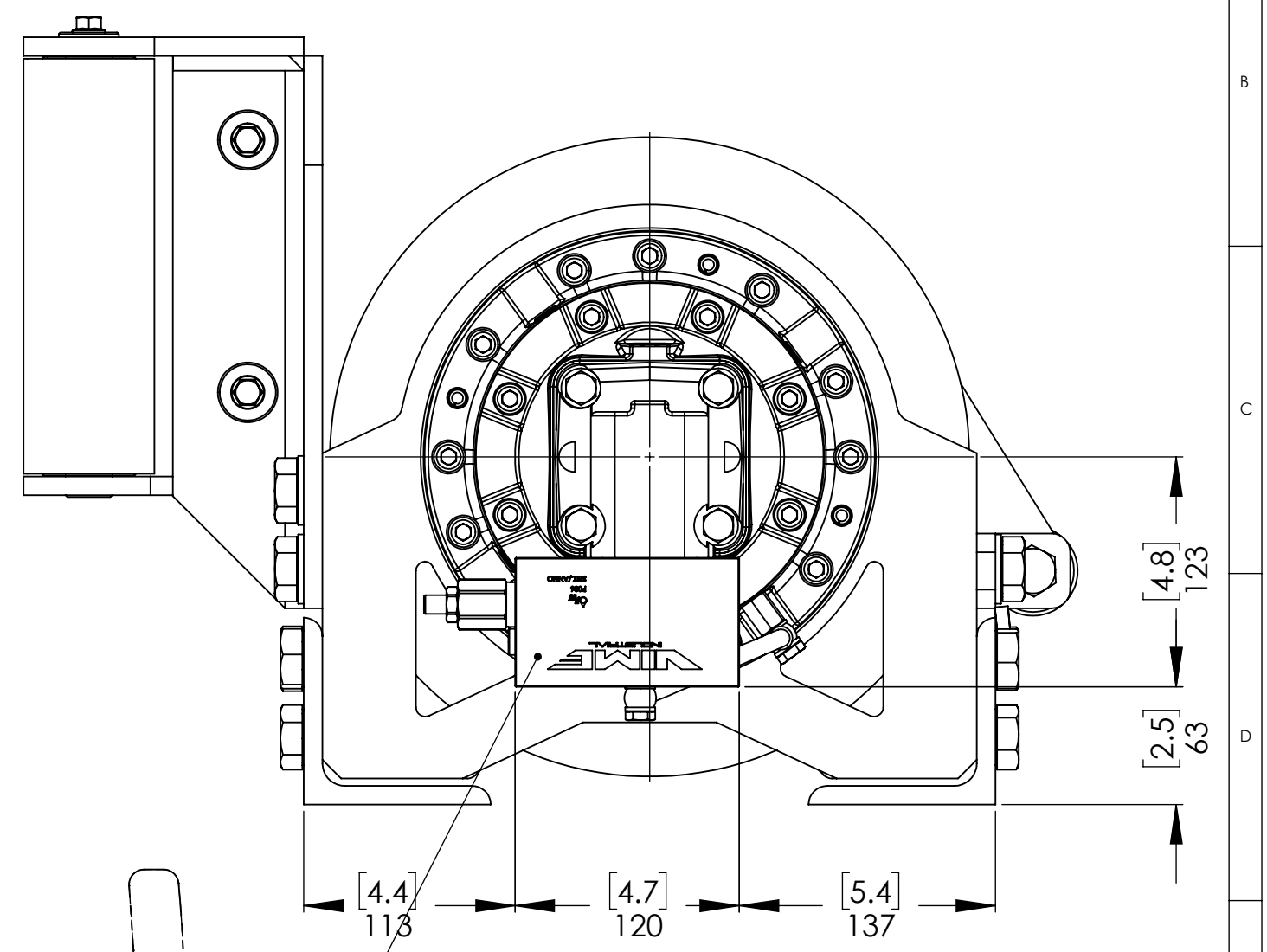
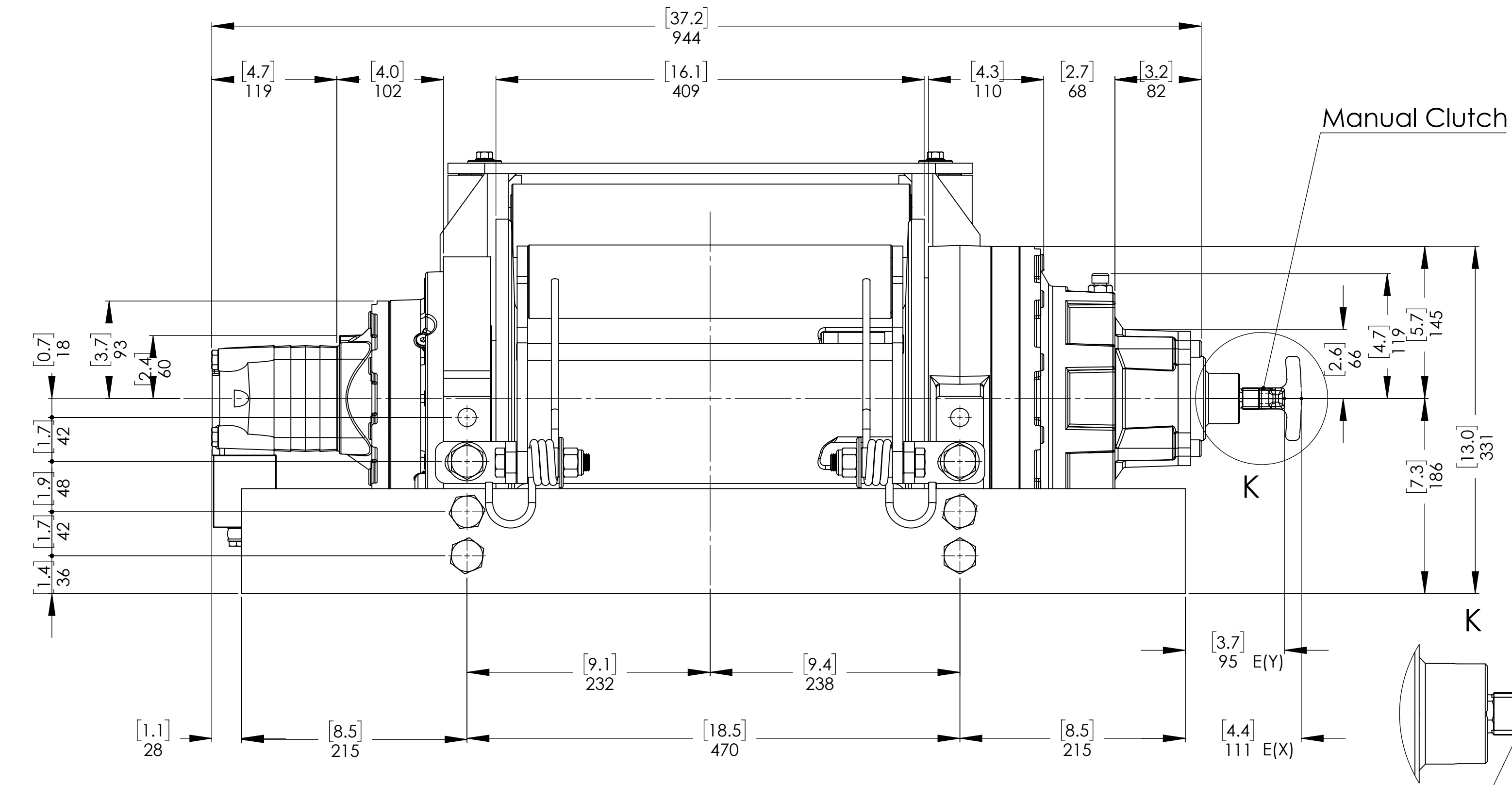
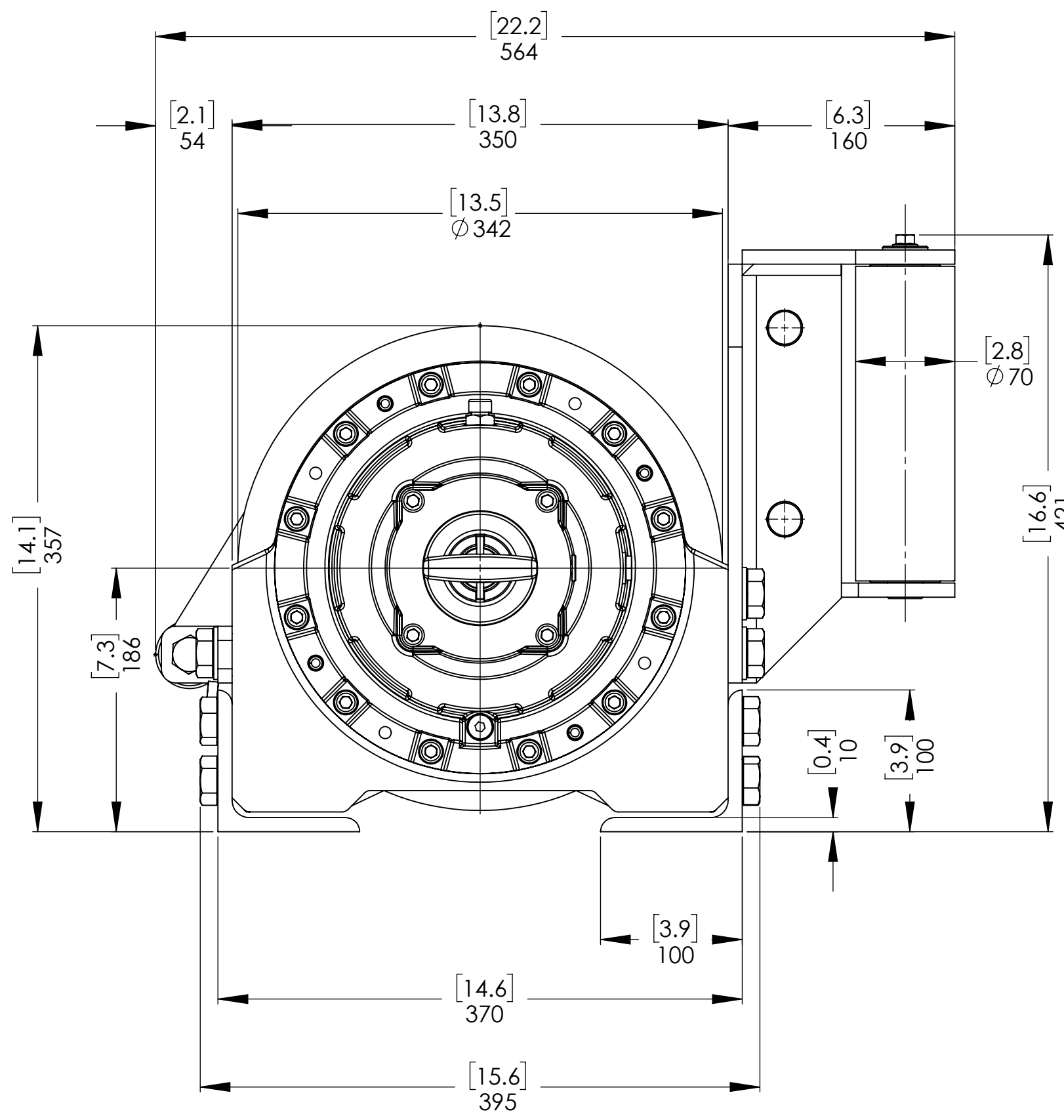

Manual Clutch

OVERCENTER VALVE POSITION*

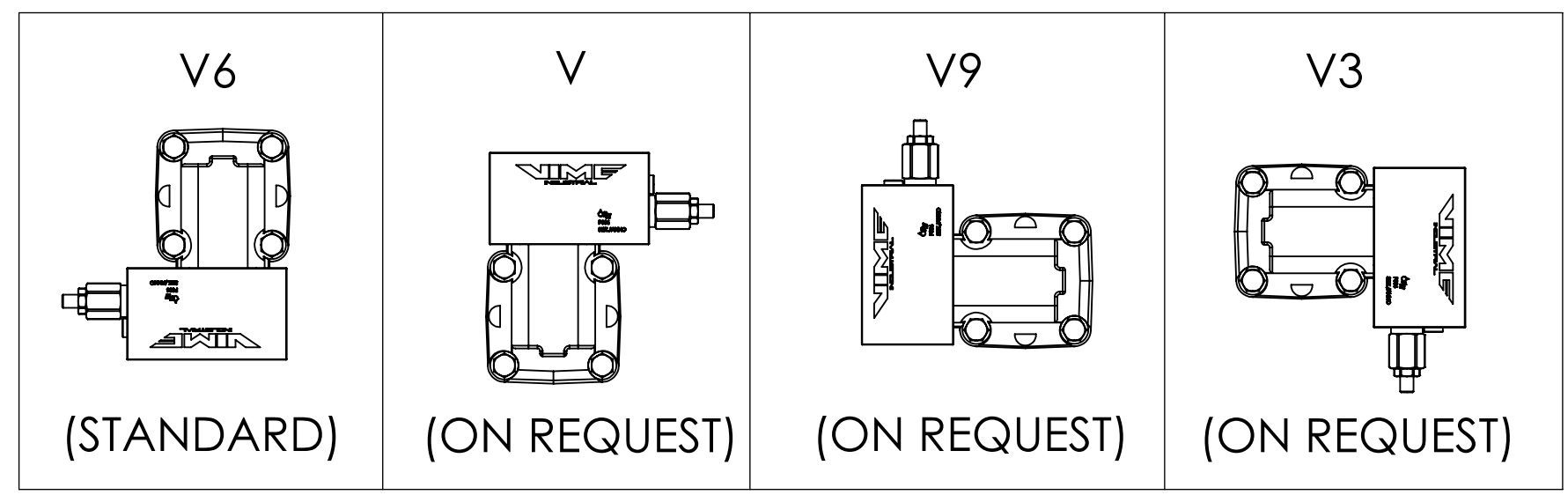

WINCH ORDERING CODE	AIR CLUTCH (STANDARD)	MANUAL CLUTCH (ON REQUEST)	HEAVY DUTY ROLLER FAIRLEAD (ON REQUEST)	CABLE TENSIONER (ON REQUEST)	OVER CENTER VALVE POSITION* (STANDARD V6)
EPHLFN100U16EAV6	X				X
EPHLFN100U16EAPV6	X			X	X
EPHLFN100U16EAGV6	X		X		X
EPHLFN100U16EAGPV6	X		X	X	X
EPHLFN100U16EV6		X			X
EPHLFN100U16EPV6		X		X	X
EPHLFN100U16EGV6		X	X		X
EPHLFN100U16EGPV6		X	X	X	X

*AT THE MOMENT OF ORDER IS POSSIBLE REQUEST THE OVERCENTER VALVE PORTS ORIENTED ACCORDING TO THE LAY OUT ABOVE. IF NOT SPECIFIED, THE WINCH WILL BE SUPPLIED WITH THE OVERCENTER VALVE PORTS ORIENTED AS PER OUR STANDARD CONFIGURATION V6.

CONNECTIONS	
V1 OUT LET	G 3/4
V2 IN LET	G 3/4
C CASE DRAIN	G 1/4
E (X) DISENGAGED	-----
E (Y) ENGAGED	-----

WINCH MODEL	EPHL 100 FN	WINCH GROUP	PLANETARY GEAR	PLUGS
Pulling capacity	10000 Kg	Date	Modification	1.Fill G 3/8
Max.Oil flow	75 Lt./Min.			2.Level G 3/8
Speed Line - first layer	11,1 Mt./Min.			3.Drain G 1/4
Speed Line - top layer	19,2 Mt./Min.	DANGEROUS: Do not use winch to lift support or transport personnel.		SCALE 1:3.5
		Gear ratio	1/22,69	WEIGHTS
		Orbital hydr. motor	160 cc	Winch (without oil) 200 Kg
		Working pressure	200 bar	Heavy-duty
		Drum size	373 mm	Roller fairlead 35 Kg
		Drum clutch	Manual	Cable tensioner 10 Kg
<p>Funo - Bologna (Italy) www.vimeindustrial.com</p> <p><i>The Quality is Transparent</i></p>		<p>VIME Industrial reserves the right to improve its products through changes in designed or materials as it may seem desirable without notice</p>		<p>DATA 19/09/2016</p> <p>COD. EPHLFN100U16EGPV6</p>

1.4.13 EPHL 100 FN CE TECHNICAL DATA

FEATURES EPHL 100 FN CE (160 cc.)	
LINE PULL FIRST LAYER	10.000 KGF
LINE SPEED FIRST LAYER	11,1 MT/MIN.
MAX. WORKING PRESSURE	200 BAR
MAX. OIL SUPPLY	75 LT/MIN
MIN. OIL SUPPLY	20 LT/MIN
WIRE ROPE SIZE (EN 14492-1)	*15/16 MM
WIRE ROPE MINIMUM BREAKING ROPE (EN 14492-1)	20.000 KG
MAX. WIRE ROPE CAPACITY (EN 14492-1)	**80/60 MT

LINE SPEED [MT/MIN]							
	OIL SUPPLY [LT/MIN]	DRUM REVOLUTION [RPM]	LINE SPEED PER LAYER [MT/MIN]				
			1	2	3	4	5
ROPE 15 MM	40	10,0	5,6	6,5	7,4	8,3	9,1
	60	15,7	8,8	10,1	11,7	13	14,5
	75	20,0	11,1	13	15	16,7	18,6
ROPE 16 MM	40	10,0	5,6	6,6	7,6	8,6	9,6
	60	15,7	8,8	10,3	11,9	13,5	15,1
	75	20,0	11,1	13,2	15,2	17,2	19,2

WIRE ROPE QUANTITY ON LAYER (DRUM LENGTH EPHL FN= 373 MM)							
LAYER	LAYER	DRUM DIAMETER [MM]		WIRE ROPE ON LAYER [MT]		WIRE ROPE QUANTITY [MT]	
		15 MM	16 MM	15 MM	16 MM	15 MM	16 MM
		6	327	338	24,5	23,7	113,4
5	297	306	22,3	21,4	88,9	84,8	
4	267	274	20,0	19,2	66,6	63,4	
3	237	242	17,8	17,0	46,6	44,2	
2	207	210	15,5	14,7	28,8	27,2	
1	177	178	13,3	12,5	13,3	12,5	
0	162	162	-	-	-	-	

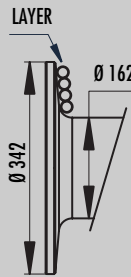

LINE PULL [KGF]			
	RATIO	LINE PULL ON [KGF]	
ROPE 15 MM	1/22,69	1	10.000
		2	8.550
		3	7.460
		4	6.600
		5	5.900
ROPE 16 MM	1/22,69	1	10.000
		2	8.470
		3	7.350
		4	6.490
		5	5.800

NOTE 

Specifications are subject to change without notification and without incurring obligation. Specifications in this publication are theoretical and may vary depending on hydraulic system, environment, etc.

*Wire rope size must be respected. Recommended wire rope min. tensile strength 2160 N/mm². Wire rope minimum breaking load must be at least double of winch max. pulling capacity.

** Max. wire rope capacity according with EN 14492-1.

WEIGHT [KG]	
WINCH (WITHOUT CABLE)	200
ACCESSORY : ROLLERFAIRLEAD	35
ACCESSORY : CABLE TENSIONER	10

1.4.14 EPHL 100 FN CE WINCH PERFORMANCE CHARTS AT THE 1ST LAYER

